

# Introduction to Machine Learning

*Dr. Mohamed El Hadi Rahmani*

*GeCoDe Laboratory  
Computer Science department  
Faculty of Technology  
University of Saida*

# Lecture Outline

- Machine learning basics
  - Supervised and unsupervised learning
  - Linear and non-linear classification methods
- Introduction to deep learning
- Elements of neural networks (NNs)
  - Activation functions
- Training NNs
  - Gradient descent
  - Regularization methods

# Machine Learning Basics

## *Machine Learning Basics*

- **Artificial Intelligence** is a scientific field concerned with the development of algorithms that allow computers to learn without being explicitly programmed
- **Machine Learning** is a branch of Artificial Intelligence, which focuses on methods that learn from data and make predictions on unseen data

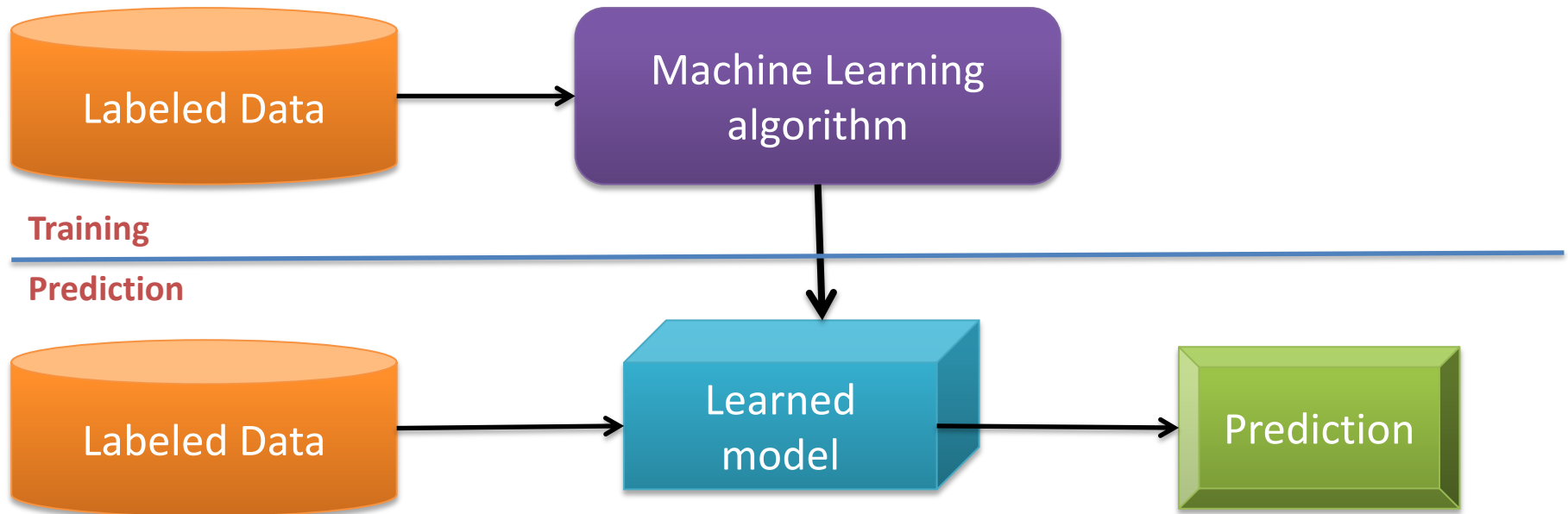

# Machine Learning Types

## Machine Learning Basics

- **Supervised**: learning with **labeled data**
  - Example: email classification, image classification
  - Example: regression for predicting real-valued outputs
- **Unsupervised**: discover patterns in **unlabeled data**
  - Example: cluster similar data points
- **Reinforcement learning**: learn to act based on **feedback/reward**
  - Example: learn to play Go

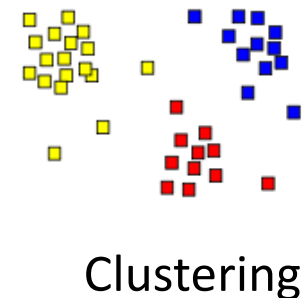
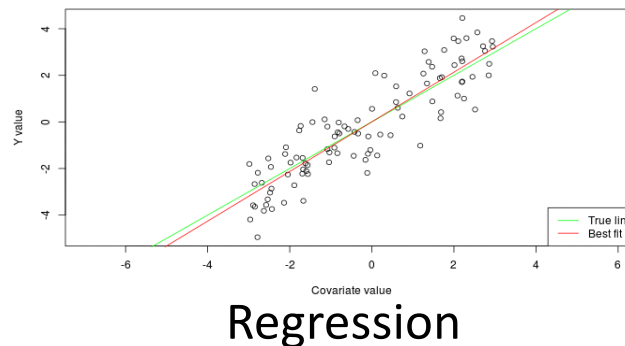
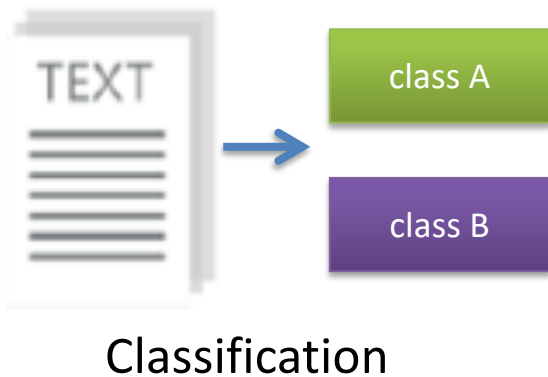

# Supervised Learning

*Machine Learning Basics*

- **Supervised learning** categories and techniques
  - **Numerical classifier functions**
    - Linear classifier, perceptron, logistic regression, support vector machines (SVM), neural networks
  - **Parametric (probabilistic) functions**
    - Naïve Bayes, Gaussian discriminant analysis (GDA), hidden Markov models (HMM), probabilistic graphical models
  - **Non-parametric (instance-based) functions**
    - $k$ -nearest neighbors, kernel regression, kernel density estimation, local regression
  - **Symbolic functions**
    - Decision trees, classification and regression trees (CART)
  - **Aggregation (ensemble) learning**
    - Bagging, boosting (Adaboost), random forest

# Unsupervised Learning

*Machine Learning Basics*

- **Unsupervised learning** categories and techniques
  - **Clustering**
    - $k$ -means clustering
    - Mean-shift clustering
    - Spectral clustering
  - **Density estimation**
    - Gaussian mixture model (GMM)
    - Graphical models
  - **Dimensionality reduction**
    - Principal component analysis (PCA)
    - Factor analysis

# Nearest Neighbor Classifier

*Machine Learning Basics*

- **Nearest Neighbor** – for each test data point, assign the class label of the nearest training data point
  - Adopt a distance function to find the nearest neighbor
    - Calculate the distance to each data point in the training set, and assign the class of the nearest data point (minimum distance)
  - It does not require learning a set of weights

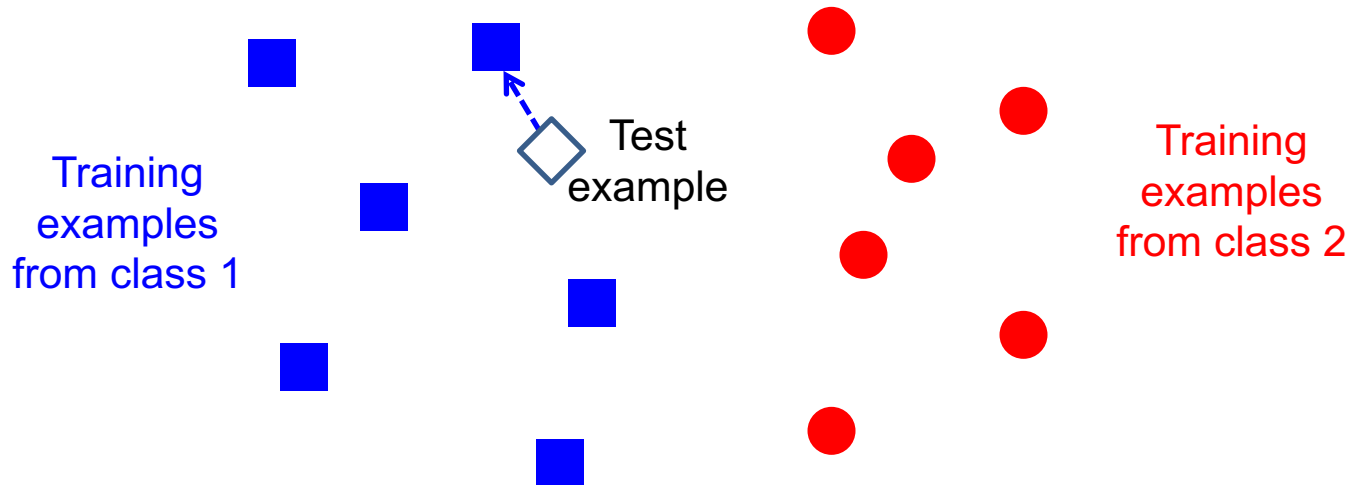

# Nearest Neighbor Classifier

*Machine Learning Basics*

- For image classification, the distance between all pixels is calculated (e.g., using  $\ell_1$  norm, or  $\ell_2$  norm)
  - Accuracy on CIFAR-10: 38.6%
- Disadvantages:
  - The classifier must remember all training data and store it for future comparisons with the test data
  - Classifying a test image is expensive since it requires a comparison to all training images

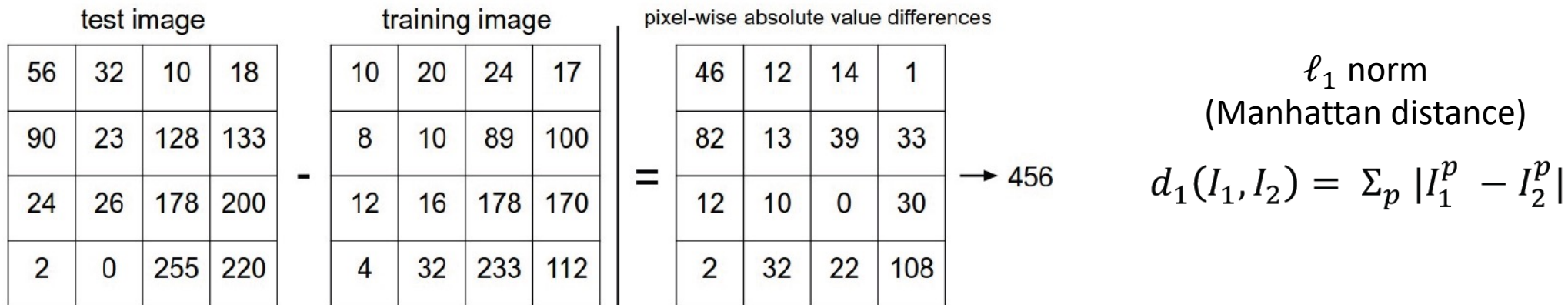



# $k$ -Nearest Neighbors Classifier

*Machine Learning Basics*

- **$k$ -Nearest Neighbors** approach considers multiple neighboring data points to classify a test data point
  - E.g., 3-nearest neighbors
    - The test example in the figure is the + mark
    - The class of the test example is obtained by voting (based on the distance to the 3 closest points)

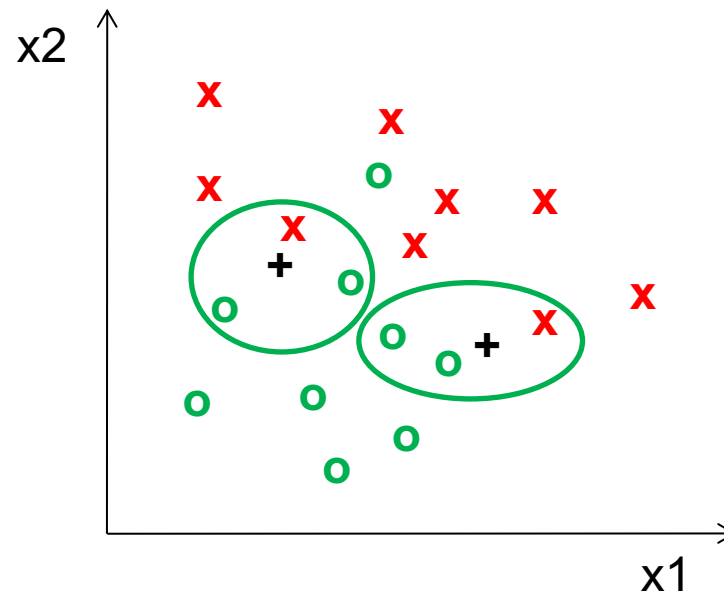

# Linear Classifier

*Machine Learning Basics*

- *Linear classifier*

- Find a linear function  $f$  of the inputs  $x_i$  that separates the classes

$$f(x_i, W, b) = Wx_i + b$$

- Use pairs of inputs and labels to find the **weights matrix**  $W$  and the **bias vector**  $b$ 
  - The weights and biases are the **parameters** of the function  $f$
- Several methods have been used to find the optimal set of parameters of a linear classifier
  - A common method of choice is the **Perceptron** algorithm, where the parameters are updated until a minimal error is reached (single layer, does not use backpropagation)
- Linear classifier is a simple approach, but it is a building block of advanced classification algorithms, such as SVM and neural networks
  - Earlier multi-layer neural networks were referred to as multi-layer perceptrons (MLPs)

# Linear Classifier

Machine Learning Basics

- The **decision boundary** is linear
  - A straight line in 2D, a flat plane in 3D, a **hyperplane** in 3D and higher dimensional space
- Example: classify an input image
  - The selected parameters in this example are not good, because the predicted cat score is low

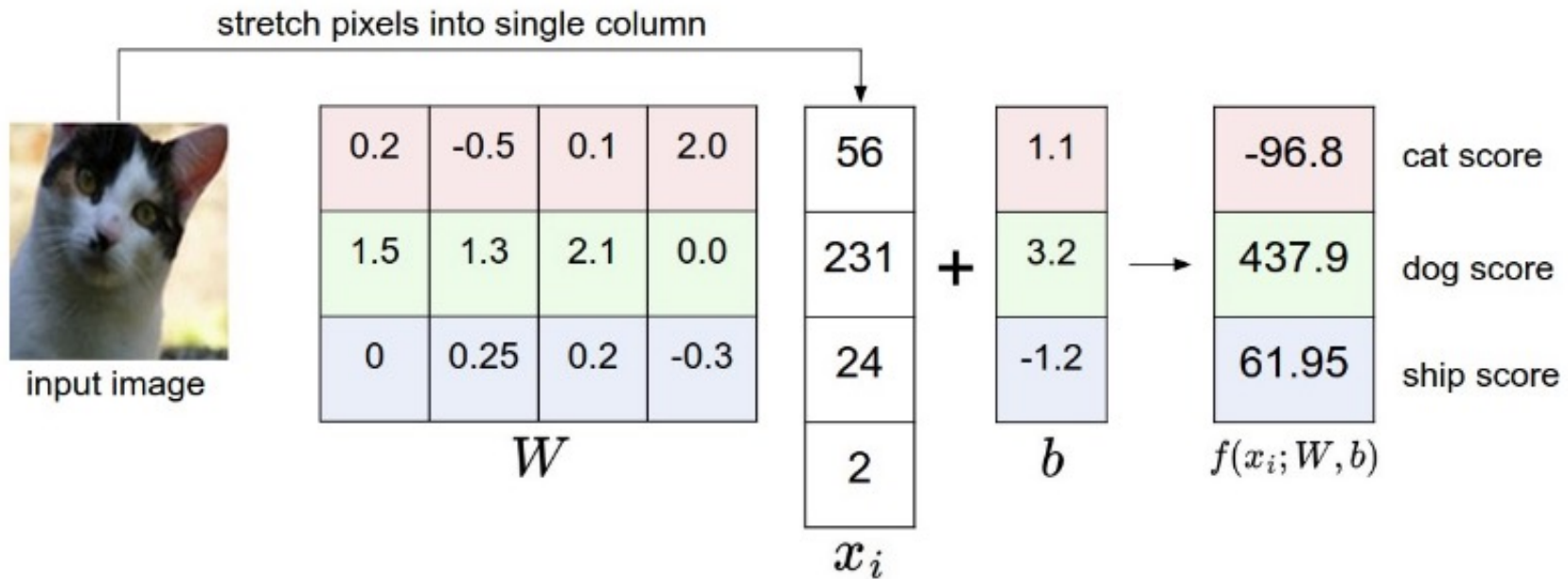
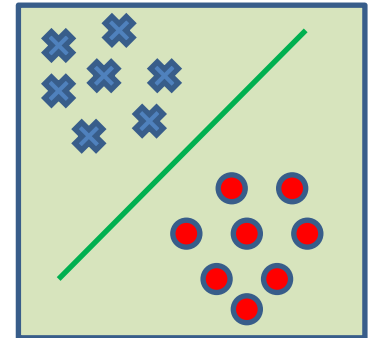

# Support Vector Machines

Machine Learning Basics

- *Support vector machines (SVM)*

- How to find the best decision boundary?
  - All lines in the figure correctly separate the 2 classes
  - The line that is farthest from all training examples will have better generalization capabilities
- SVM solves an optimization problem:
  - First, identify a **decision boundary** that correctly classifies the examples
  - Next, increase the geometric margin between the boundary and all examples
- The data points that define the maximum margin width are called **support vectors**
- Find  $W$  and  $b$  by solving:

$$\min \frac{1}{2} \|w\|^2$$
$$s.t. y_i (w \cdot x_i + b) \geq 1, \quad \forall x_i$$

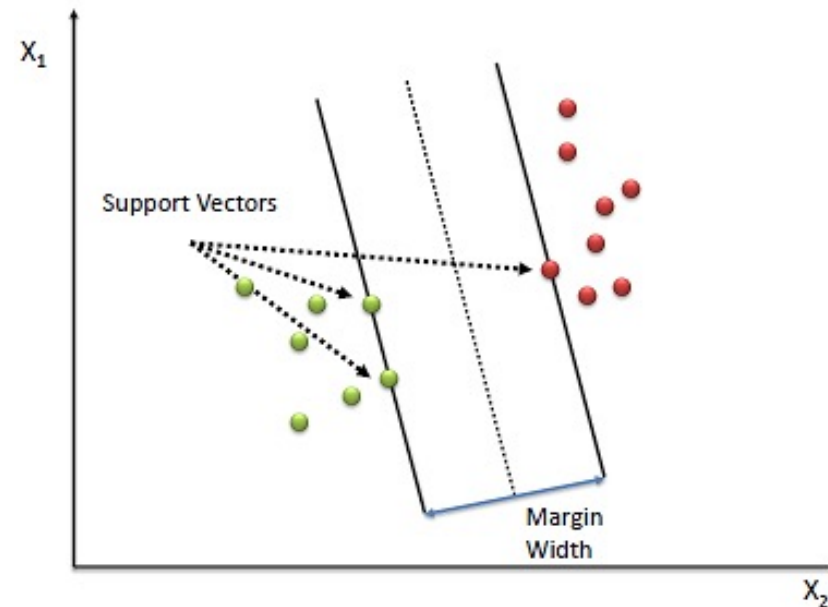
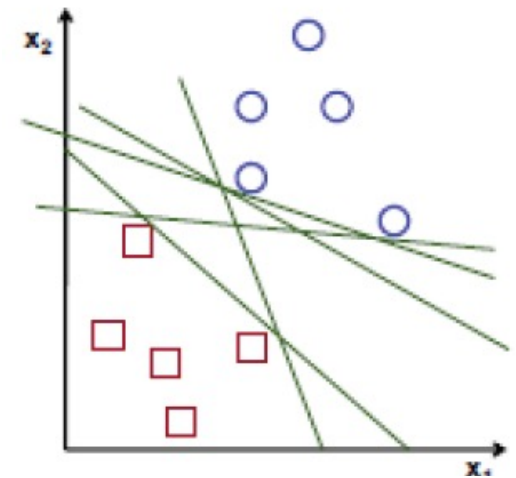

# Linear vs Non-linear Techniques

*Linear vs Non-linear Techniques*

- Linear classification techniques
  - Linear classifier
  - Perceptron
  - Logistic regression
  - Linear SVM
  - Naïve Bayes
- Non-linear classification techniques
  - $k$ -nearest neighbors
  - Non-linear SVM
  - Neural networks
  - Decision trees
  - Random forest

# Linear vs Non-linear Techniques

## *Linear vs Non-linear Techniques*

- For some tasks, input data can be linearly separable, and linear classifiers can be suitably applied

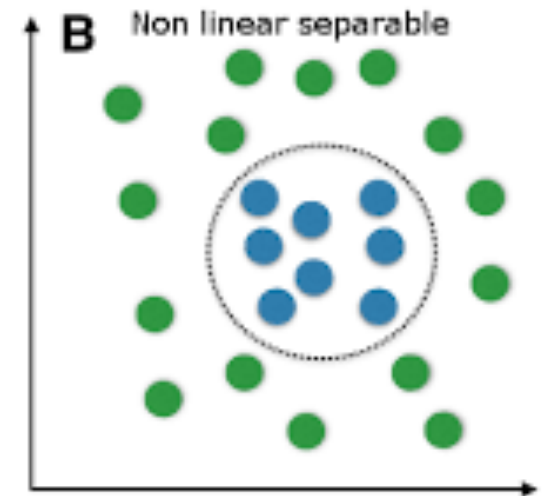
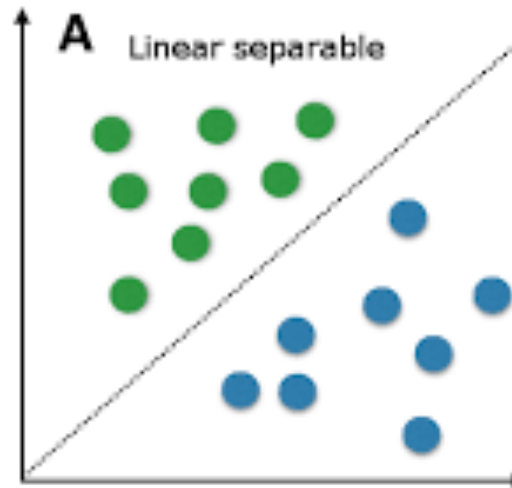

- For other tasks, linear classifiers may have difficulties to produce adequate decision boundaries

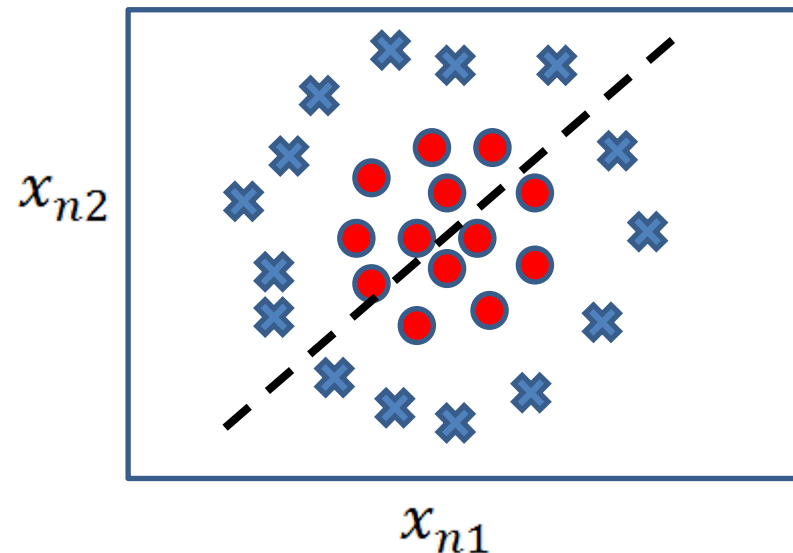

# Non-linear Techniques

## Linear vs Non-linear Techniques

- Non-linear classification
  - Features  $z_i$  are obtained as **non-linear functions** of the inputs  $x_i$
  - It results in non-linear decision boundaries
  - Can deal with non-linearly separable data

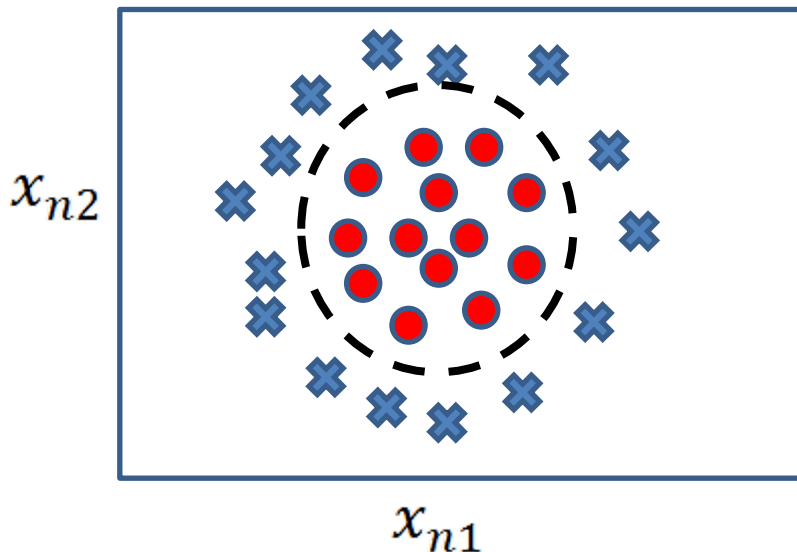

Inputs:  $x_i = [x_{n1} \quad x_{n2}]$



Features:  $z_i = [x_{n1} \quad x_{n2} \quad x_{n1} \cdot x_{n2} \quad x_{n1}^2 \quad x_{n2}^2]$



Outputs:  $f(x_i, W, b) = Wz_i + b$

# Non-linear Support Vector Machines

*Linear vs Non-linear Techniques*

- **Non-linear SVM**

- The original input space is mapped to a higher-dimensional feature space where the training set is linearly separable
- Define a non-linear kernel function to calculate a non-linear decision boundary in the original feature space

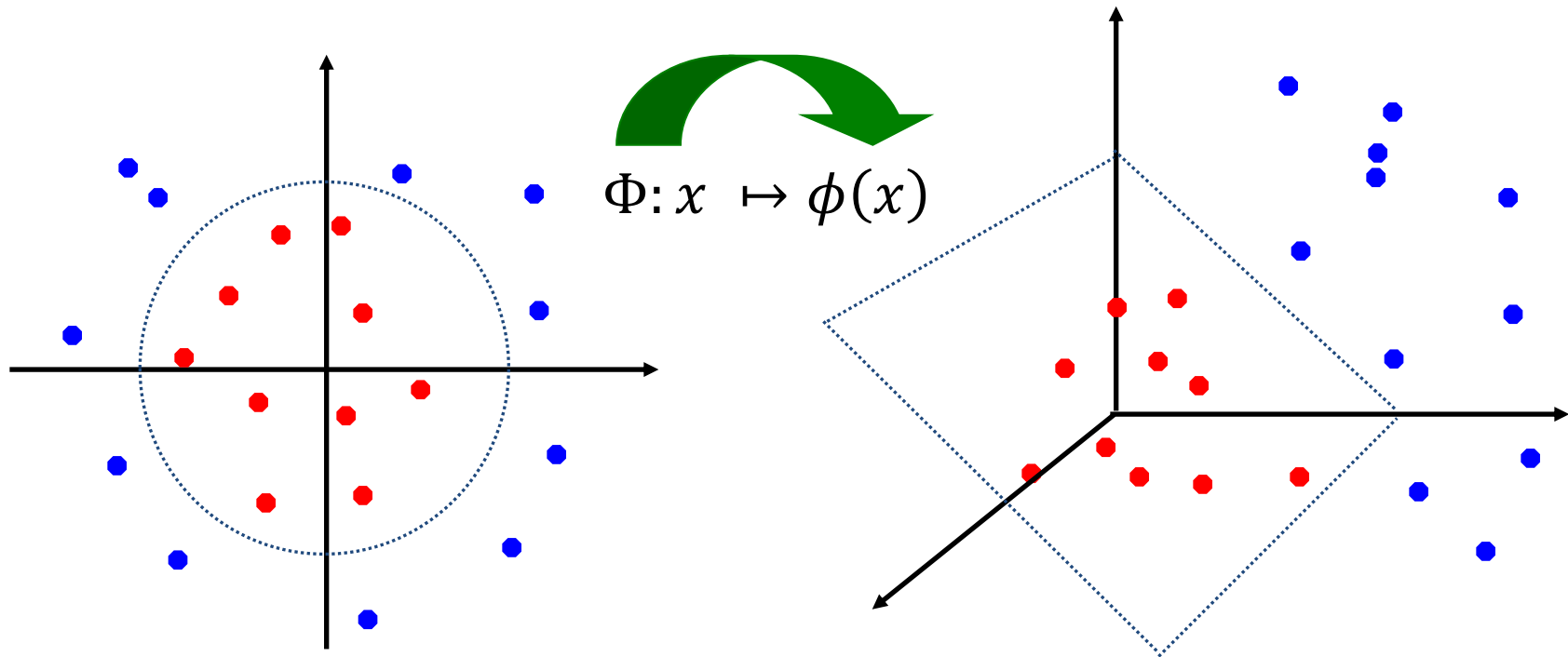



# Binary vs Multi-class Classification

## *Binary vs Multi-class Classification*

- A classification problem with only 2 classes is referred to as *binary classification*
  - The output labels are 0 or 1
  - E.g., benign or malignant tumor, spam or no-spam email
- A problem with 3 or more classes is referred to as *multi-class classification*

Binary classification:

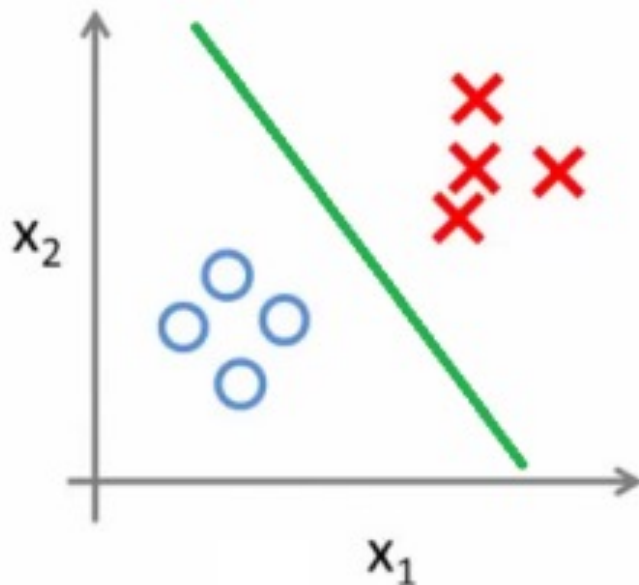

Multi-class classification:

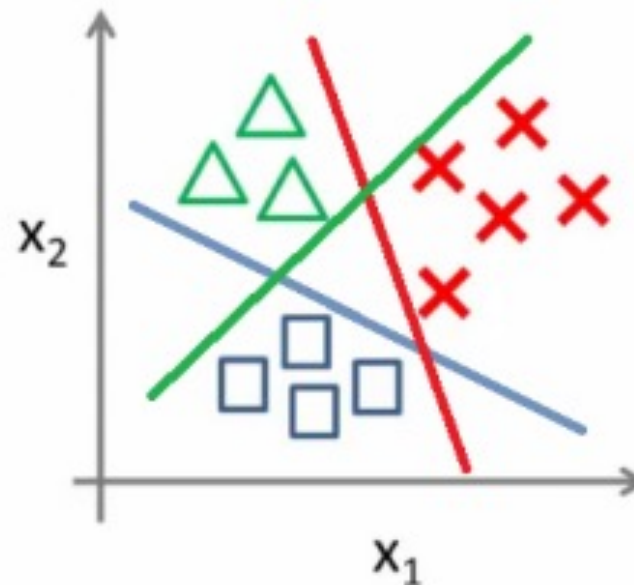

# Binary vs Multi-class Classification

## *Binary vs Multi-class Classification*

- Both the binary and multi-class classification problems can be linearly or non-linearly separated
  - Figure: linearly and non-linearly separated data for binary classification problem

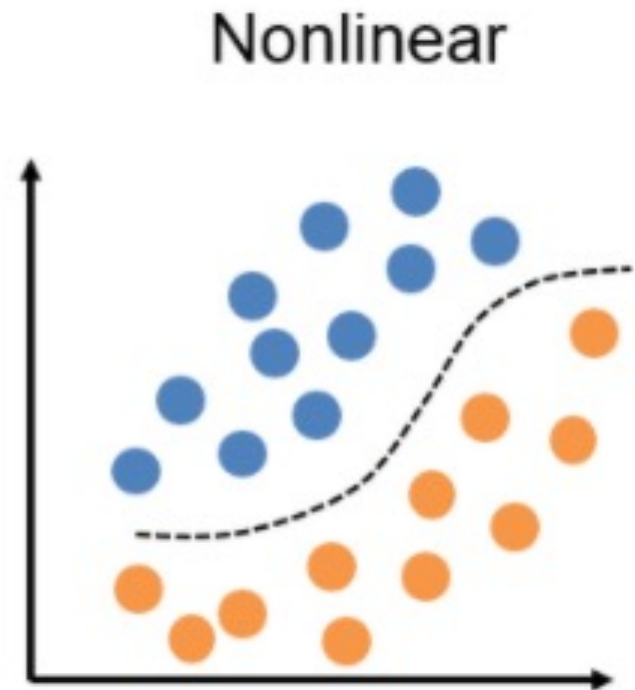
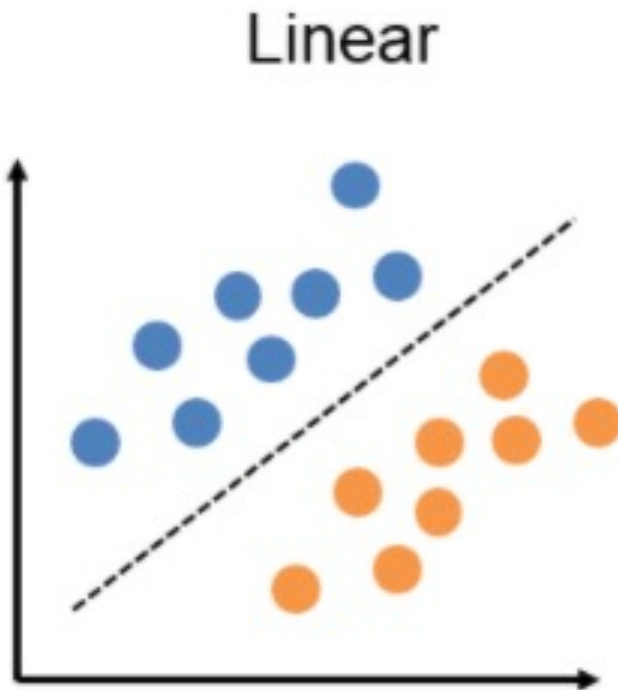

# Computer Vision Tasks

*Machine Learning Basics*

- Computer vision has been the primary area of interest for ML
- The tasks include: classification, localization, object detection, instance segmentation

**Classification**



CAT

**Classification  
+ Localization**



CAT

**Object Detection**

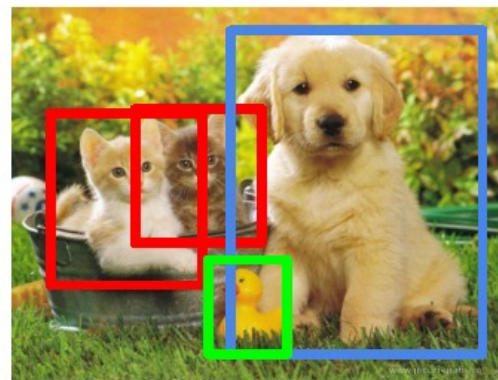

CAT, DOG, DUCK

**Instance Segmentation**



CAT, DOG, DUCK

Single object

Multiple objects

# ML vs. Deep Learning

*Introduction to Deep Learning*

- Conventional machine learning methods rely on **human-designed feature representations**
  - ML becomes just optimizing weights to best make a final prediction

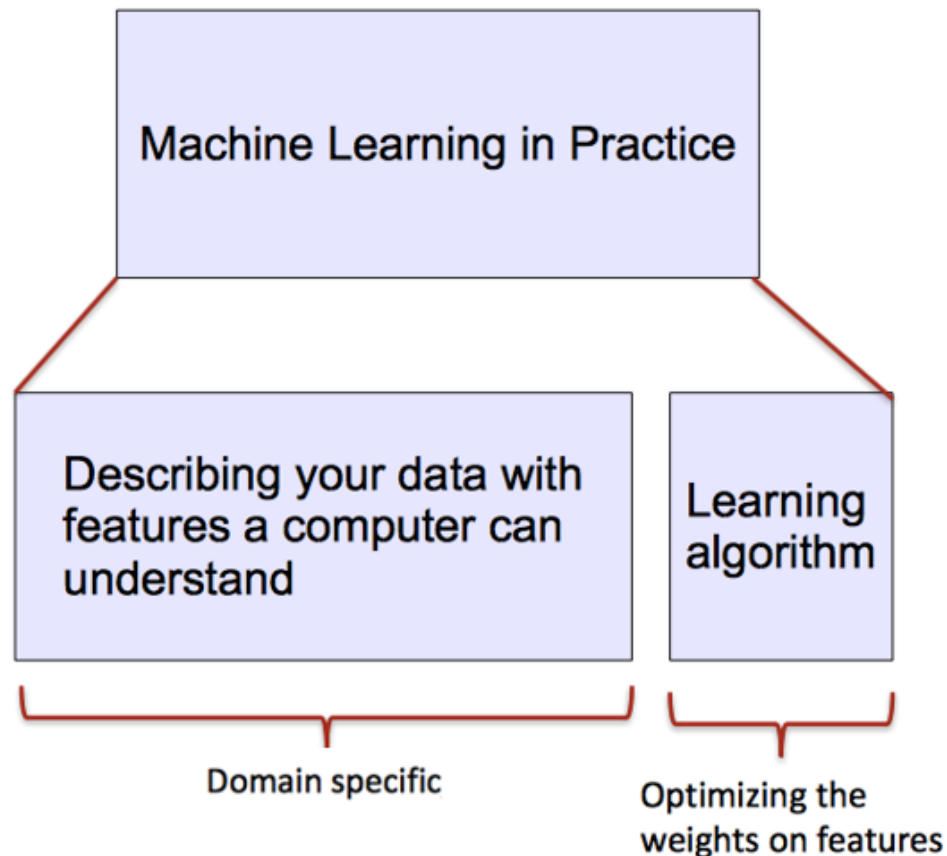

# ML vs. Deep Learning

## *Introduction to Deep Learning*

- **Deep learning** (DL) is a machine learning subfield that uses multiple layers for learning data representations
  - DL is exceptionally effective at learning patterns

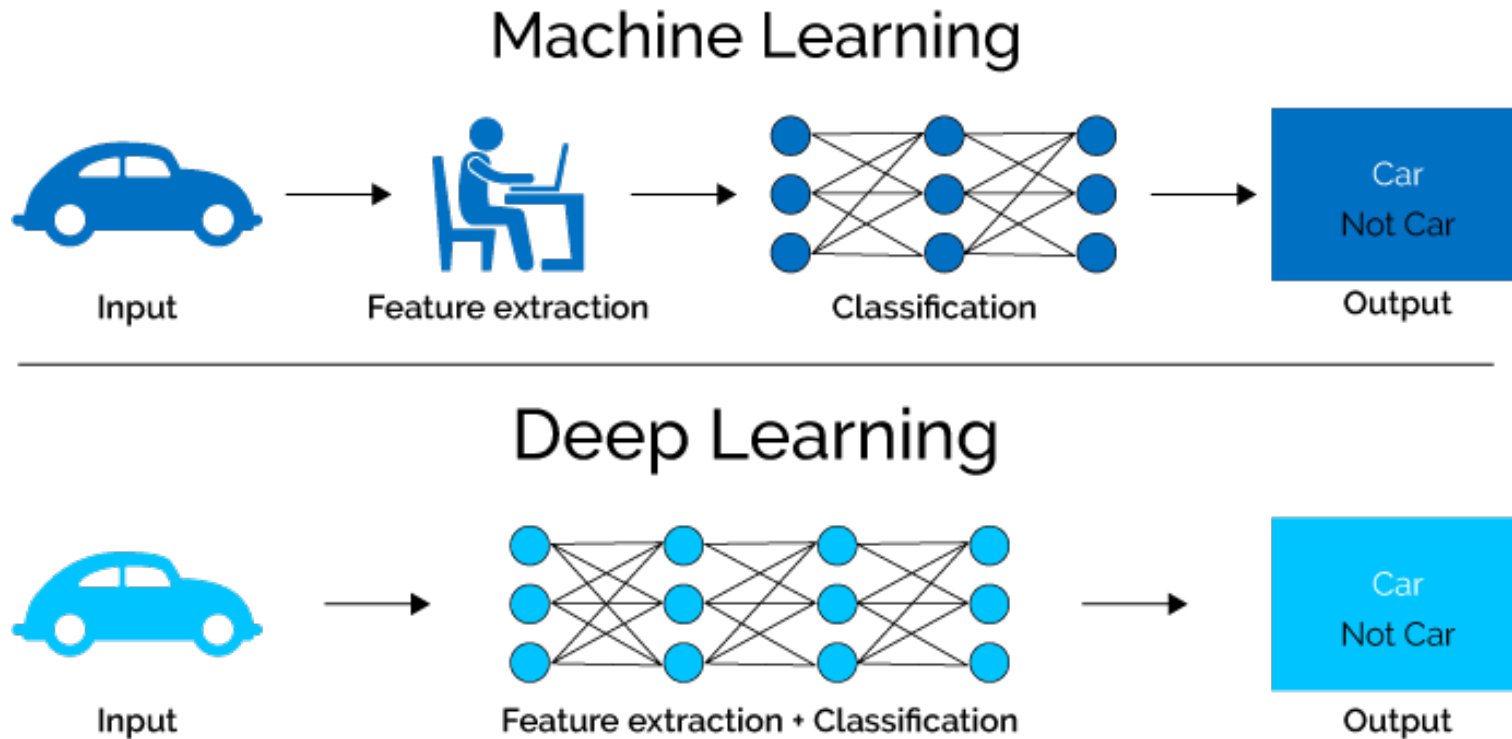

# ML vs. Deep Learning

## *Introduction to Deep Learning*

- DL applies a multi-layer process for learning rich hierarchical features (i.e., data representations)
  - Input image pixels → Edges → Textures → Parts → Objects

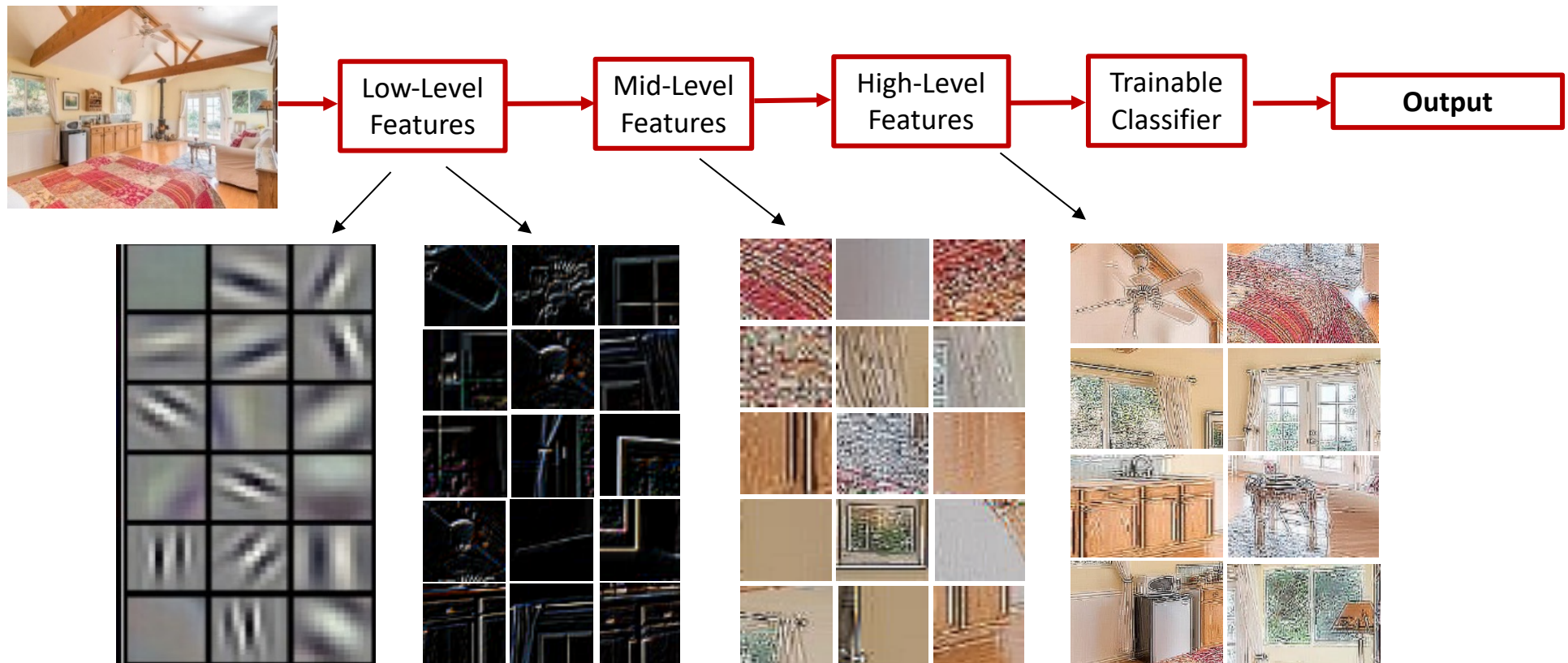

# Why is DL Useful?

*Introduction to Deep Learning*

- DL provides a flexible, learnable framework for representing visual, text, linguistic information
  - Can learn in supervised and unsupervised manner
- DL represents an effective end-to-end learning system
- Requires large amounts of training data
- Since about 2010, DL has outperformed other ML techniques
  - First in vision and speech, then NLP, and other applications

# Representational Power

*Introduction to Deep Learning*

- NNs with at least one hidden layer are **universal approximators**
  - Given any continuous function  $h(x)$  and some  $\epsilon > 0$ , there exists a NN with one hidden layer (and with a reasonable choice of non-linearity) described with the function  $f(x)$ , such that  $\forall x, |h(x) - f(x)| < \epsilon$
  - I.e., NN can approximate any arbitrary complex continuous function
- NNs use nonlinear mapping of the inputs  $x$  to the outputs  $f(x)$  to compute complex decision boundaries
- But then, why use deeper NNs?
  - The fact that deep NNs work better is an empirical observation
  - Mathematically, deep NNs have the same representational power as a one-layer NN

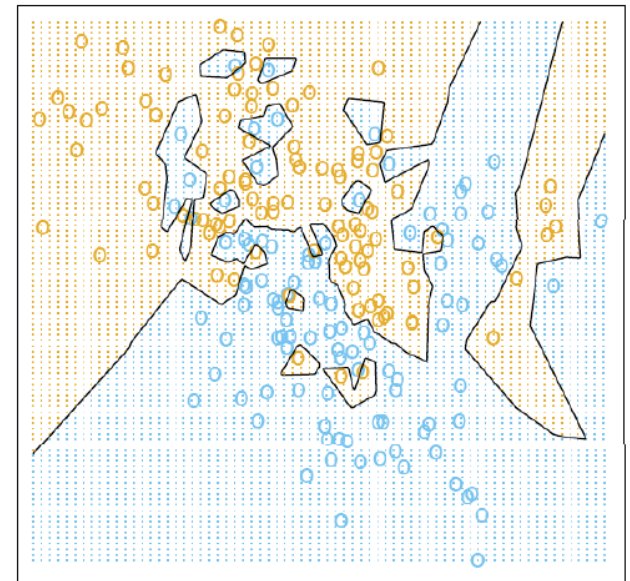



# Introduction to Neural Networks

*Introduction to Neural Networks*

- Handwritten digit recognition (**MNIST dataset**)
  - The intensity of each pixel is considered an **input** element
  - **Output** is the class of the digit

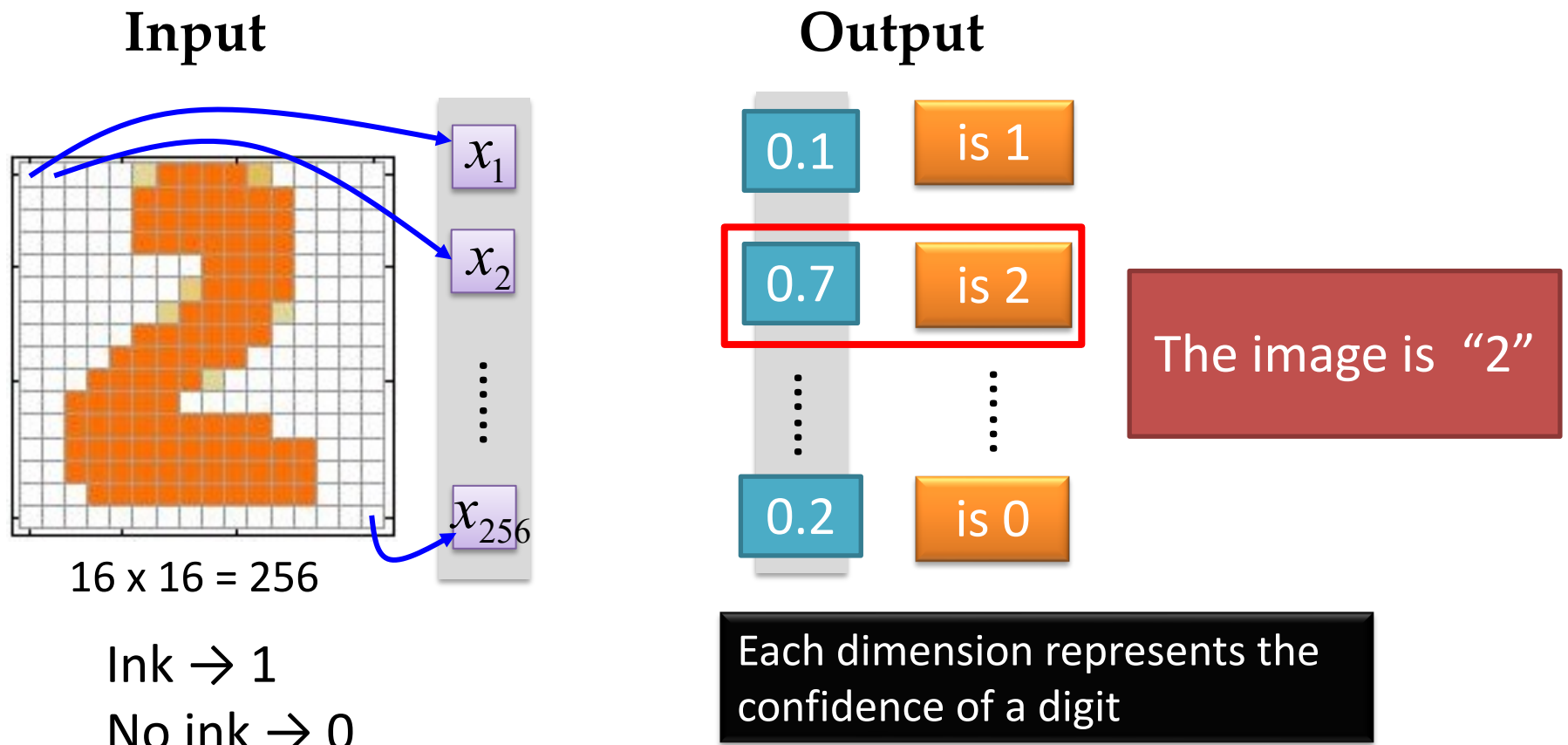

# Introduction to Neural Networks

*Introduction to Neural Networks*

- Handwritten digit recognition

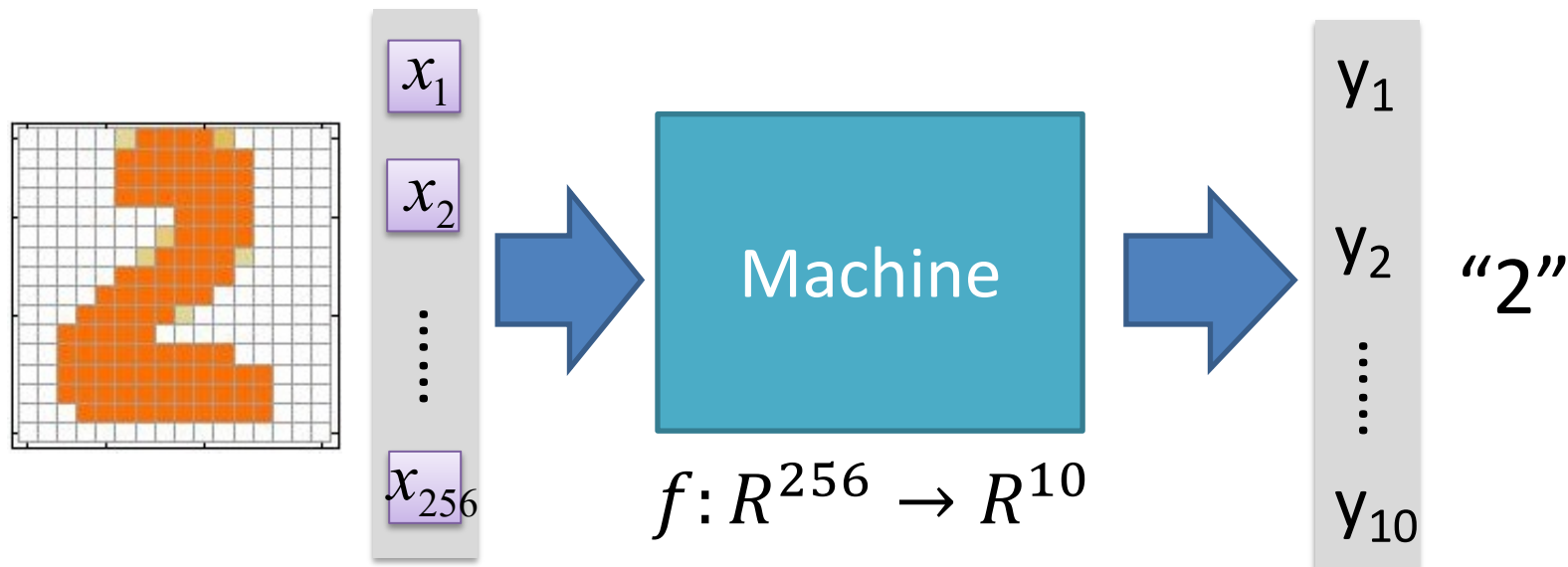

The function  $f$  is represented by a neural network

# Elements of Neural Networks

*Introduction to Neural Networks*

- NNs consist of hidden layers with neurons (i.e., computational units)
- A single **neuron** maps a set of inputs into an output number, or  $f: R^K \rightarrow R$

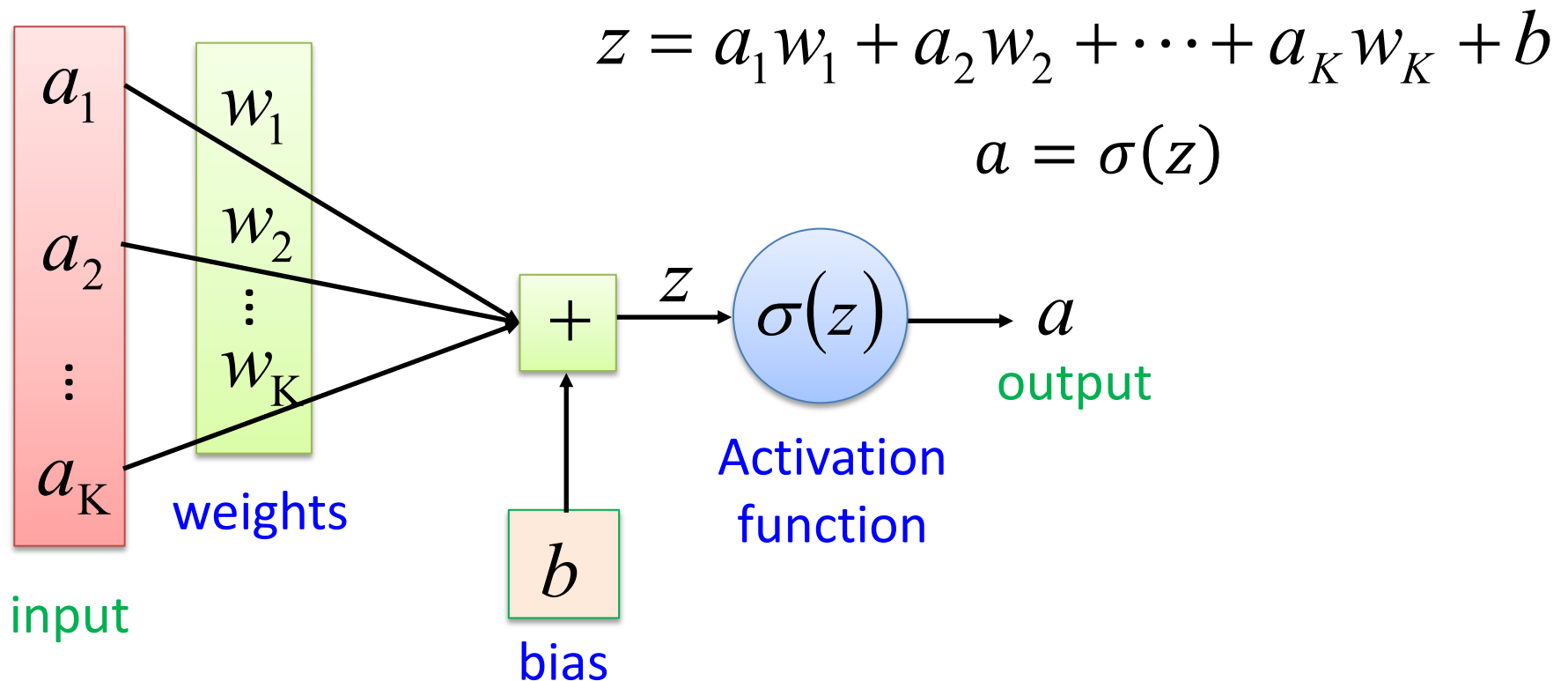

# Elements of Neural Networks

Introduction to Neural Networks

- A NN with one hidden layer and one output layer

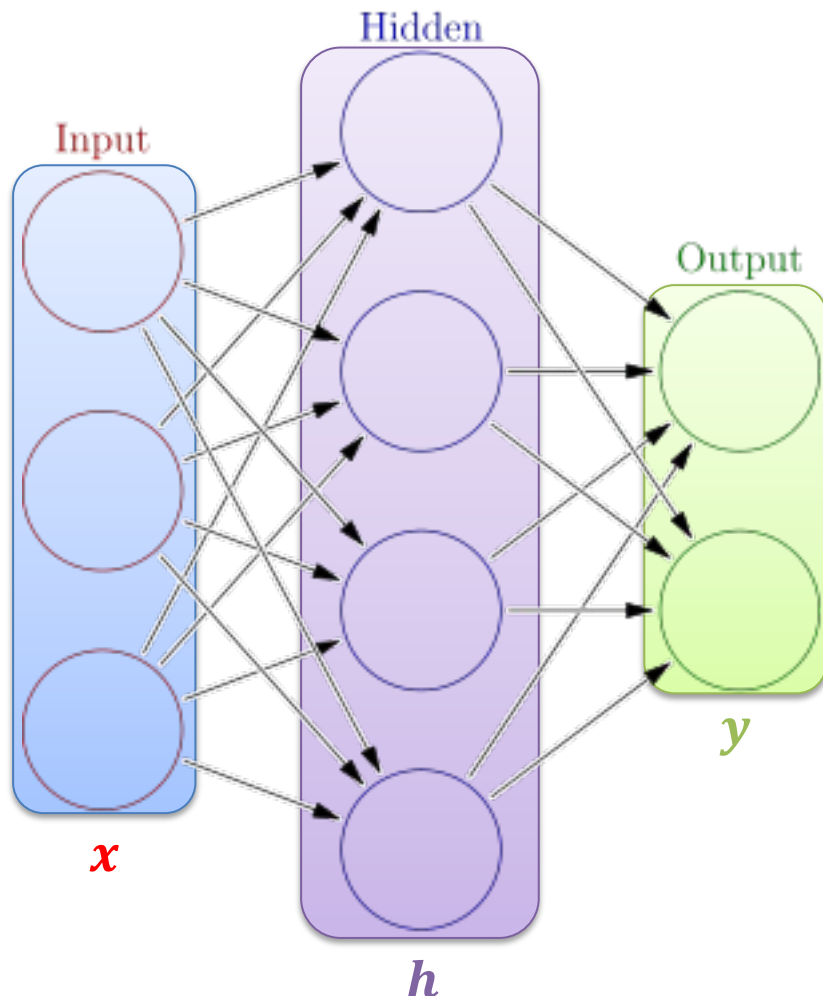

Weights      Biases

$$\text{hidden layer } h = \sigma(W_1x + b_1)$$
$$\text{output layer } y = \sigma(W_2h + b_2)$$

Activation functions

$$4 + 2 = 6 \text{ neurons (not counting inputs)}$$
$$[3 \times 4] + [4 \times 2] = 20 \text{ weights}$$
$$4 + 2 = 6 \text{ biases}$$

---

$$26 \text{ learnable parameters}$$

# Elements of Neural Networks

Introduction to Neural Networks

- A neural network playground [link](#)

Tinker With a **Neural Network** Right Here in Your Browser.  
Don't Worry, You Can't Break It. We Promise.

The screenshot displays a neural network playground interface. At the top, there are controls for Epoch (000,452), Learning rate (0.03), Activation (Tanh), Regularization (None), Regularization rate (0), and Problem type (Classification). Below these are buttons for refresh, play, and next.

The main interface is divided into several sections:

- DATA:** Includes a dropdown for dataset selection, a slider for the ratio of training to test data (set to 50%), a slider for noise (set to 0), and a slider for batch size (set to 10). A "REGENERATE" button is also present.
- FEATURES:** A list of input features including  $X_1$ ,  $X_2$ ,  $X_1^2$ ,  $X_2^2$ ,  $X_1X_2$ ,  $\sin(X_1)$ , and  $\sin(X_2)$ . Each feature has a corresponding colored square icon.
- 2 HIDDEN LAYERS:** A diagram showing a network with 6 neurons in the first hidden layer and 2 neurons in the second hidden layer. Lines of varying thickness connect the neurons, representing weights. A tooltip indicates: "The outputs are mixed with varying weights, shown by the thickness of the lines." Another tooltip points to a neuron: "This is the output from one neuron. Hover to see it larger."
- OUTPUT:** A scatter plot showing the output of the network. The plot has axes ranging from -6 to 6. A legend indicates that colors show data, neuron, and weight values. A color scale from -1 (orange) to 1 (blue) is provided. A checkbox for "Show test data" is unchecked, and a checkbox for "Discretize output" is checked. The plot shows a central cluster of blue points surrounded by orange points.

At the top right of the output section, the following metrics are displayed: Test loss 0.005 and Training loss 0.001, accompanied by a small line graph showing the loss over time.

# Elements of Neural Networks

*Introduction to Neural Networks*

- Deep NNs have many hidden layers
  - **Fully-connected (dense)** layers (a.k.a. **Multi-Layer Perceptron** or MLP)
  - Each neuron is connected to all neurons in the succeeding layer

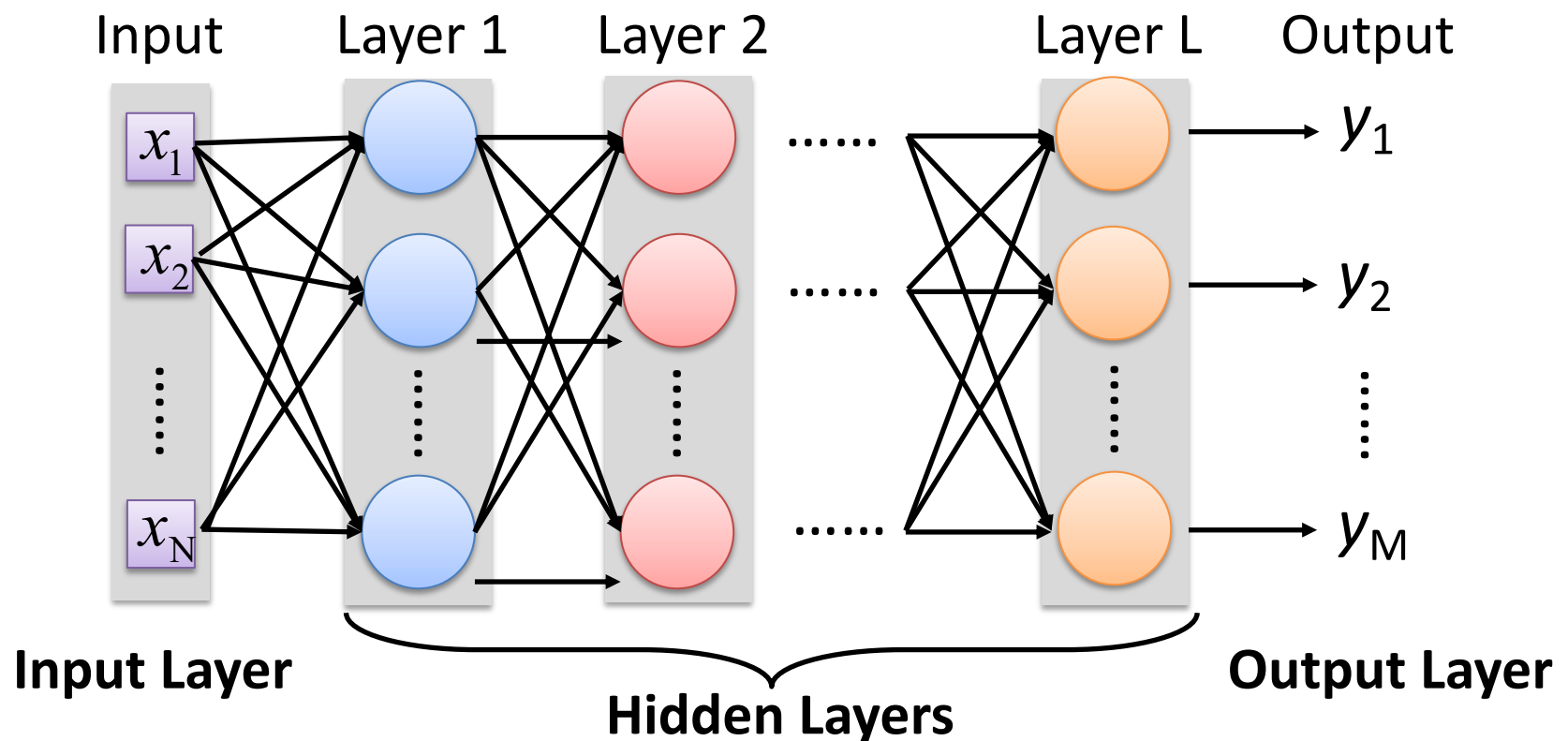

# Elements of Neural Networks

*Introduction to Neural Networks*

- A simple network, toy example

$$(1 \cdot 1) + (-1) \cdot (-2) + 1 = 4$$

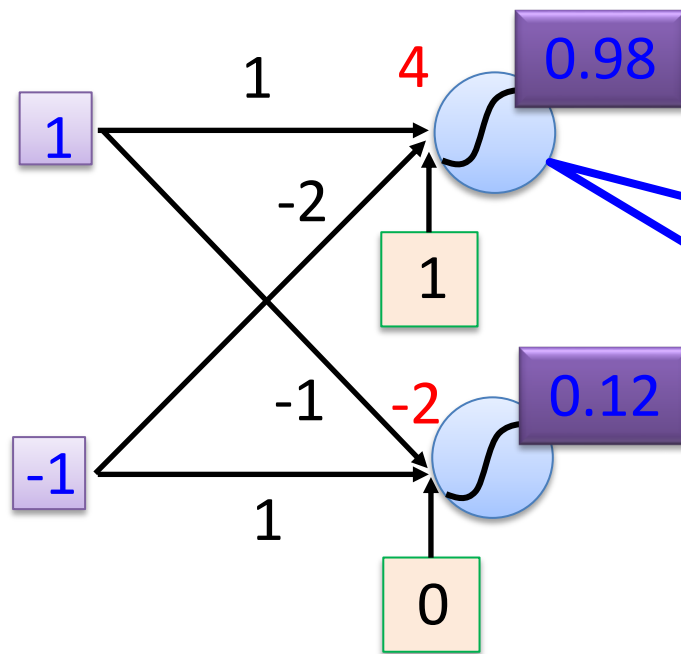

Sigmoid Function

$$\sigma(z) = \frac{1}{1 + e^{-z}}$$

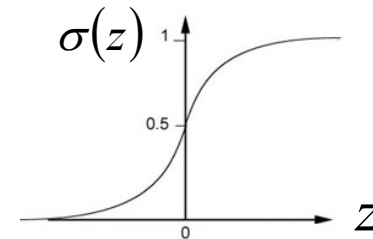

$$1 \cdot (-1) + (-1) \cdot 1 + 0 = -2$$

# Elements of Neural Networks

*Introduction to Neural Networks*

- A simple network, toy example (cont'd)
  - For an input vector  $[1 \ -1]^T$ , the output is  $[0.62 \ 0.83]^T$

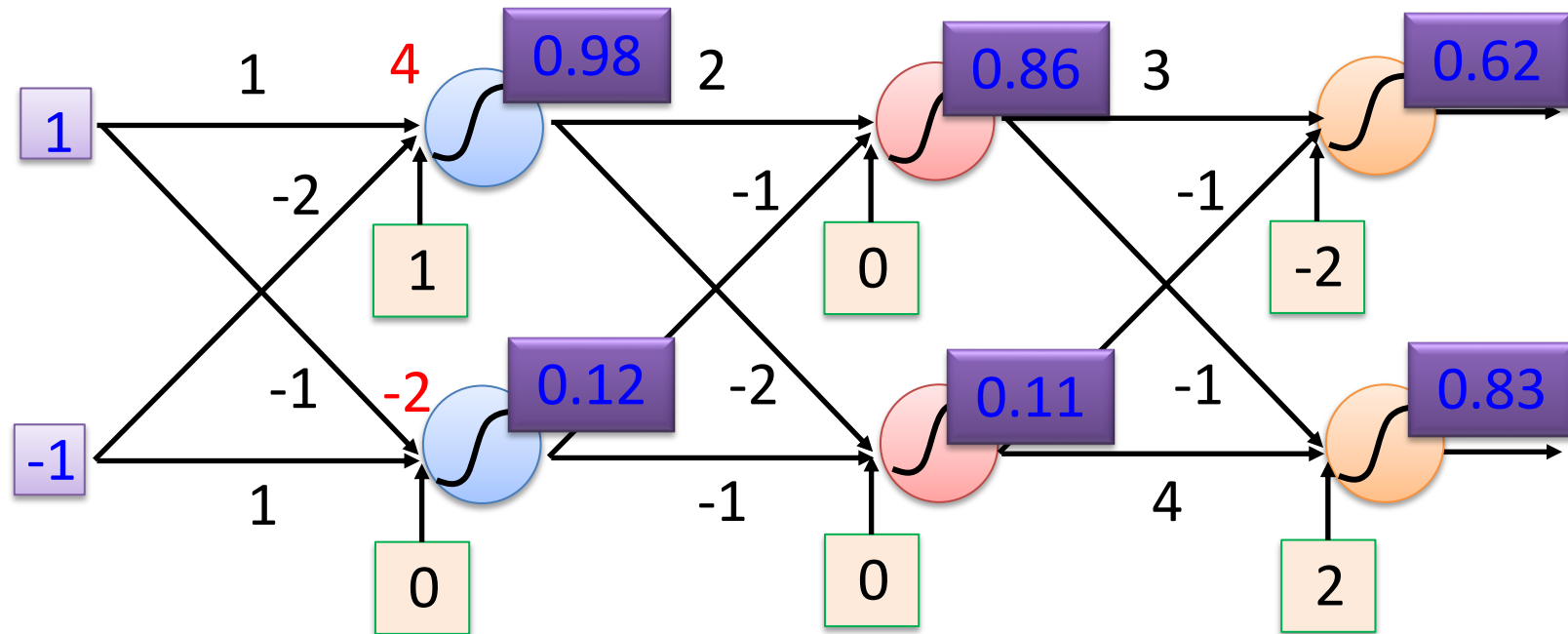

$$f: \mathbb{R}^2 \rightarrow \mathbb{R}^2 \quad f\left(\begin{bmatrix} 1 \\ -1 \end{bmatrix}\right) = \begin{bmatrix} 0.62 \\ 0.83 \end{bmatrix}$$



# Matrix Operation

*Introduction to Neural Networks*

- Matrix operations are helpful when working with multidimensional inputs and outputs

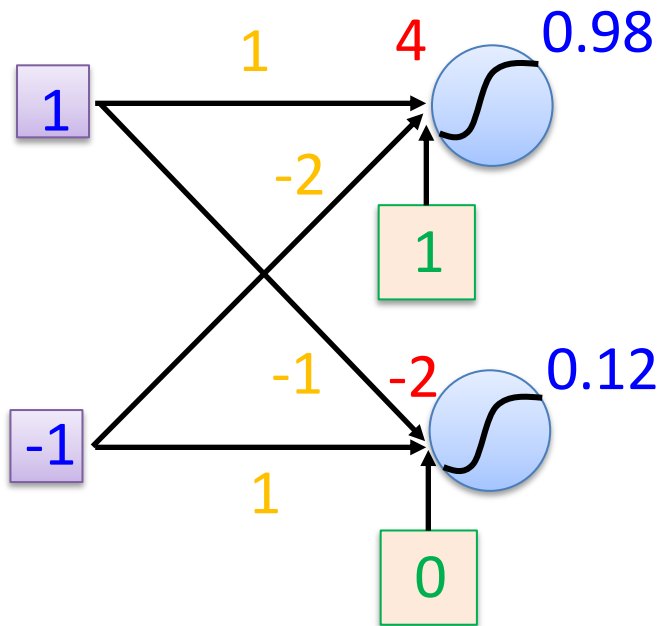

$$\sigma( W x + b ) = a$$
$$\sigma( \underbrace{\begin{bmatrix} 1 & -2 \\ -1 & 1 \end{bmatrix} \begin{bmatrix} 1 \\ -1 \end{bmatrix} + \begin{bmatrix} 1 \\ 0 \end{bmatrix}}_{\begin{bmatrix} 4 \\ -2 \end{bmatrix}} ) = \begin{bmatrix} 0.98 \\ 0.12 \end{bmatrix}$$

# Matrix Operation

*Introduction to Neural Networks*

- Multilayer NN, matrix calculations for the first layer
  - Input vector  $x$ , weights matrix  $W^1$ , bias vector  $b^1$ , output vector  $a^1$

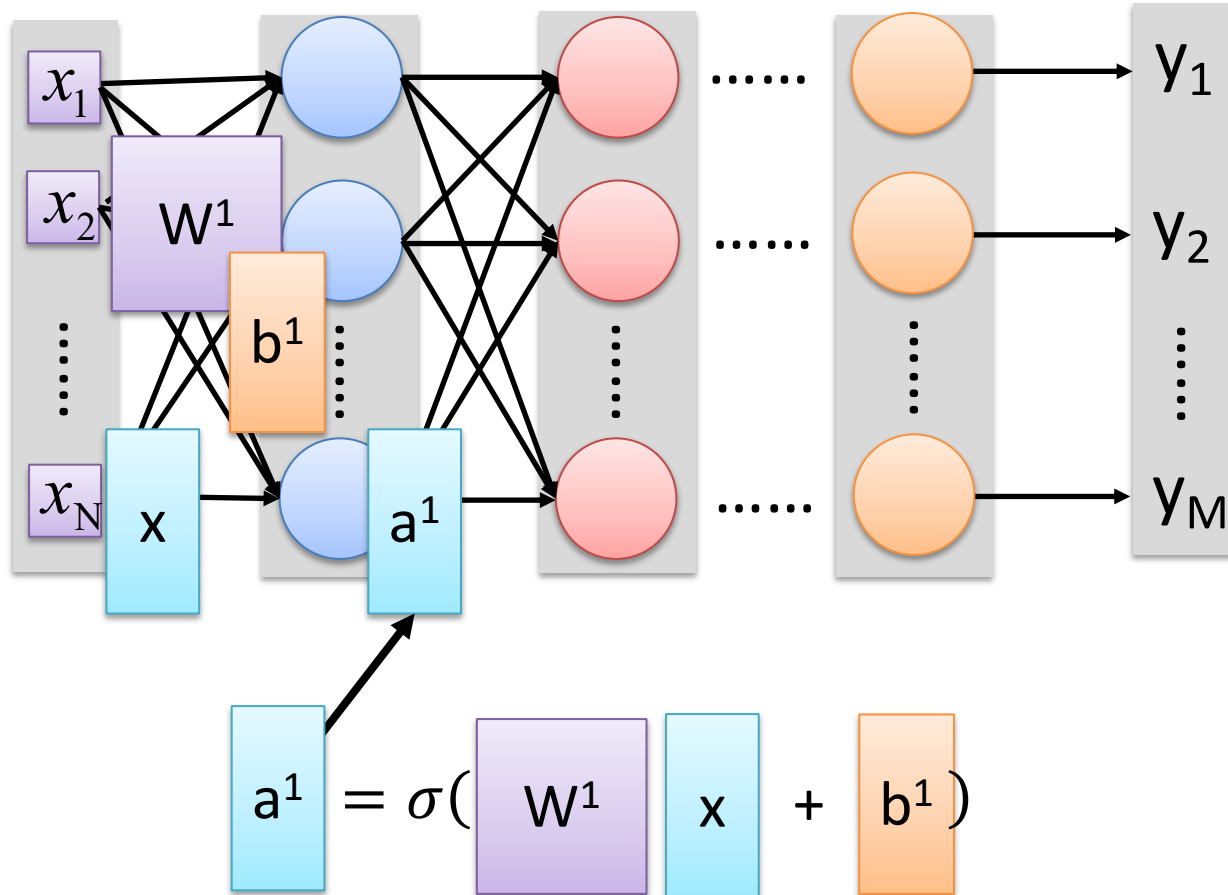

# Matrix Operation

*Introduction to Neural Networks*

- Multilayer NN, matrix calculations for all layers

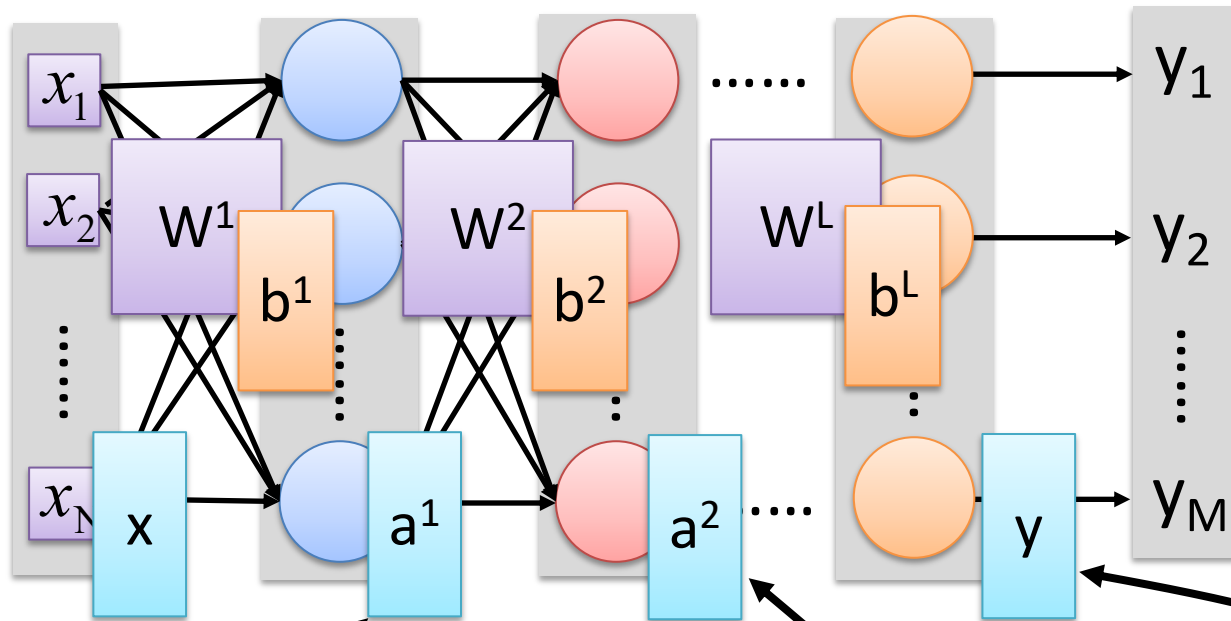

$$\sigma(W^1 x + b^1) \rightarrow \sigma(W^2 a^1 + b^2) \rightarrow \dots \rightarrow \sigma(W^L a^{L-1} + b^L) \rightarrow y$$

The diagram shows the matrix operations for each layer. The first layer operation is  $\sigma(W^1 x + b^1)$ , the second is  $\sigma(W^2 a^1 + b^2)$ , and the final layer is  $\sigma(W^L a^{L-1} + b^L)$ . Arrows indicate the flow of data from the input  $x$  through the hidden layers  $a^1, a^2, \dots, a^{L-1}$  to the output  $y$ .

# Matrix Operation

*Introduction to Neural Networks*

- Multilayer NN, function  $f$  maps inputs  $x$  to outputs  $y$ , i.e.,  $y = f(x)$

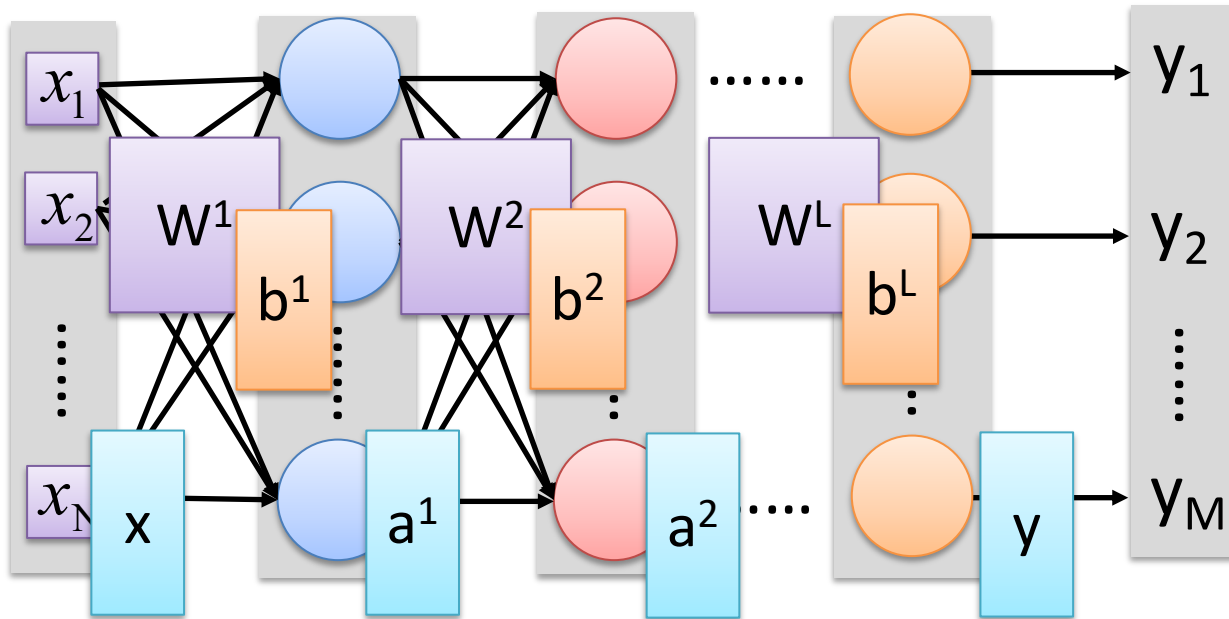

$$y = f(x) = \sigma(W^L \dots \sigma(W^2 \sigma(W^1 x + b^1) + b^2) \dots + b^L)$$

# Softmax Layer

Introduction to Neural Networks

- In **multi-class classification** tasks, the output layer is typically a *softmax layer*
  - I.e., it employs a *softmax activation function*
  - If a layer with a sigmoid activation function is used as the output layer instead, the predictions by the NN may not be easy to interpret
    - Note that an output layer with sigmoid activations can still be used for binary classification

## A Layer with Sigmoid Activations

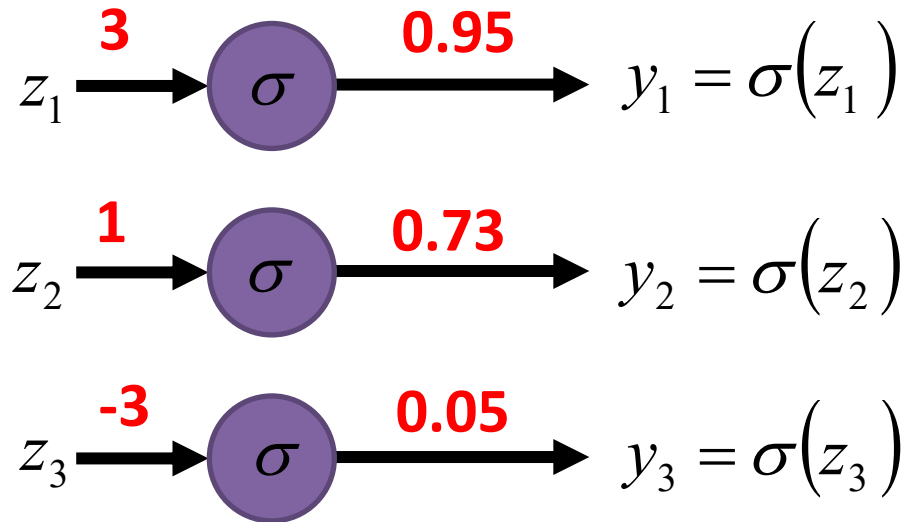

# Softmax Layer

Introduction to Neural Networks

- The **softmax layer** applies softmax activations to output a probability value in the range  $[0, 1]$ 
  - The values  $z$  inputted to the softmax layer are referred to as *logits*

**Probability:**

- $0 < y_i < 1$
- $\sum_i y_i = 1$

## A Softmax Layer

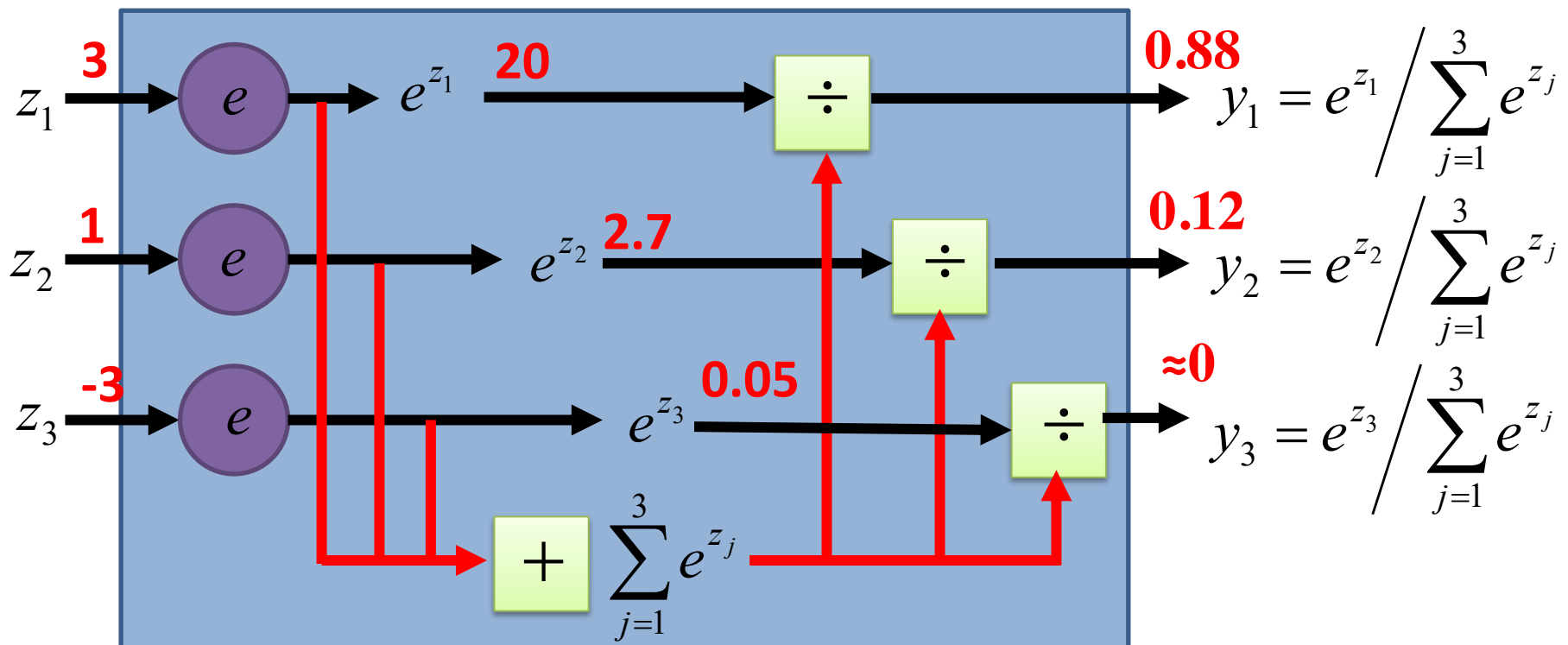

# Activation Functions

*Introduction to Neural Networks*

- **Non-linear activations** are needed to learn complex (non-linear) data representations
  - Otherwise, NNs would be just a linear function (such as  $W_1 W_2 x = Wx$ )
  - NNs with large number of layers (and neurons) can approximate more complex functions
    - Figure: more neurons improve representation (but, may overfit)

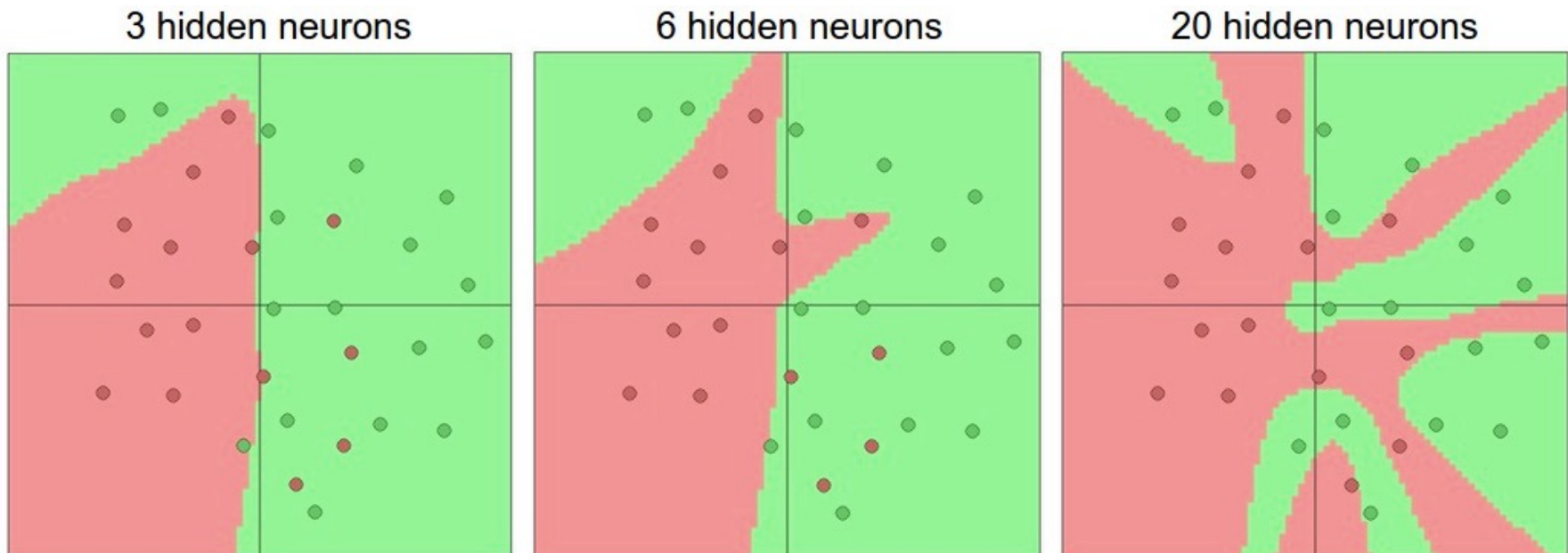

# Activation: Sigmoid

*Introduction to Neural Networks*

- **Sigmoid function**  $\sigma$ : takes a real-valued number and “squashes” it into the range between 0 and 1
  - The output can be interpreted as the firing rate of a biological neuron
    - Not firing = 0; Fully firing = 1
  - When the neuron’s activation are 0 or 1, sigmoid neurons saturate
    - Gradients at these regions are almost zero (almost no signal will flow)
  - Sigmoid activations are less common in modern NNs

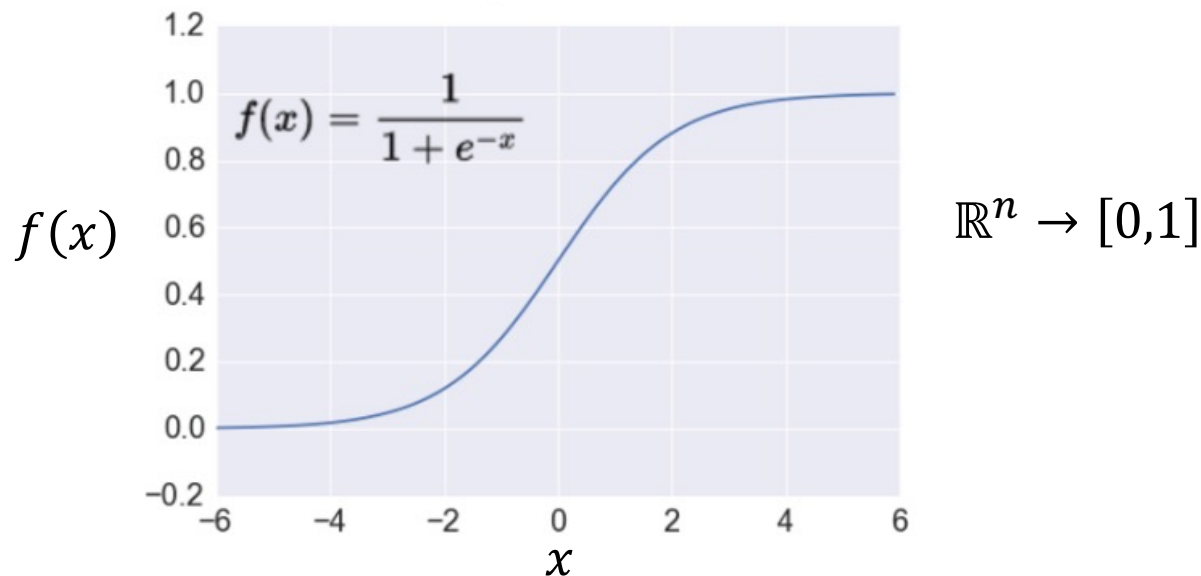



# Activation: Tanh

*Introduction to Neural Networks*

- **Tanh function:** takes a real-valued number and “squashes” it into range between -1 and 1
  - Like sigmoid, tanh neurons saturate
  - Unlike sigmoid, the output is zero-centered
    - It is therefore preferred than sigmoid
  - Tanh is a scaled sigmoid:  $\tanh(x) = 2 \cdot \sigma(2x) - 1$

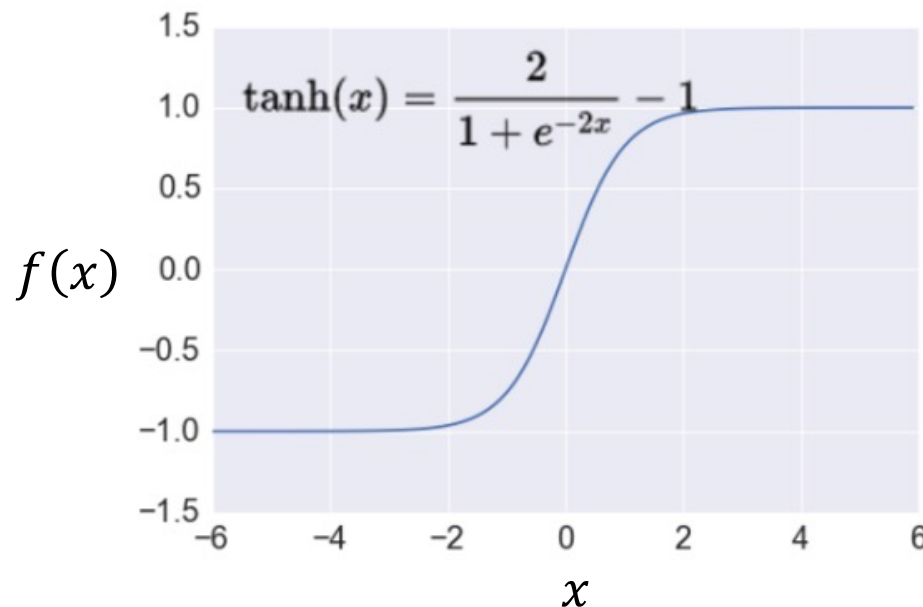

$$\mathbb{R}^n \rightarrow [-1,1]$$

# Activation: ReLU

*Introduction to Neural Networks*

- **ReLU** (Rectified Linear Unit): takes a real-valued number and thresholds it at zero

$$f(x) = \max(0, x)$$

- Most modern deep NNs use ReLU activations
- ReLU is fast to compute
  - Compared to sigmoid, tanh
  - Simply threshold a matrix at zero
- Accelerates the convergence of gradient descent
  - Due to linear, non-saturating form
- Prevents the gradient vanishing problem

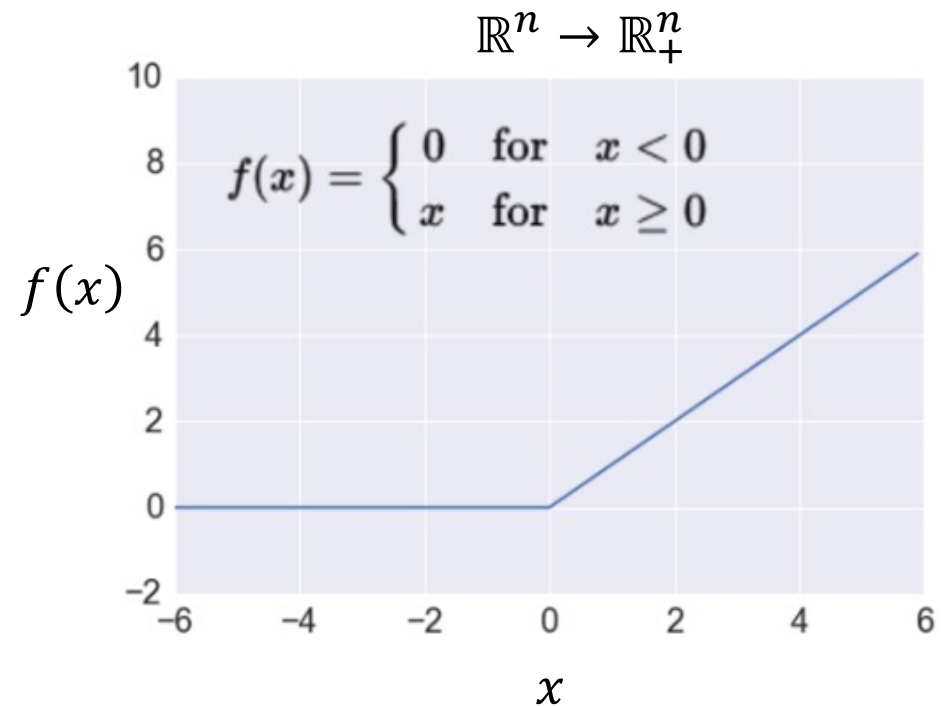

# Activation: Leaky ReLU

*Introduction to Neural Networks*

- The problem of ReLU activations: they can “die”
  - ReLU could cause weights to update in a way that the gradients can become zero and the neuron will not activate again on any data
  - E.g., when a large learning rate is used
- **Leaky ReLU** activation function is a variant of ReLU
  - Instead of the function being 0 when  $x < 0$ , a leaky ReLU has a small negative slope (e.g.,  $\alpha = 0.01$ , or similar)
  - This resolves the dying ReLU problem
  - Most current works still use ReLU
    - With a proper setting of the learning rate, the problem of dying ReLU can be avoided

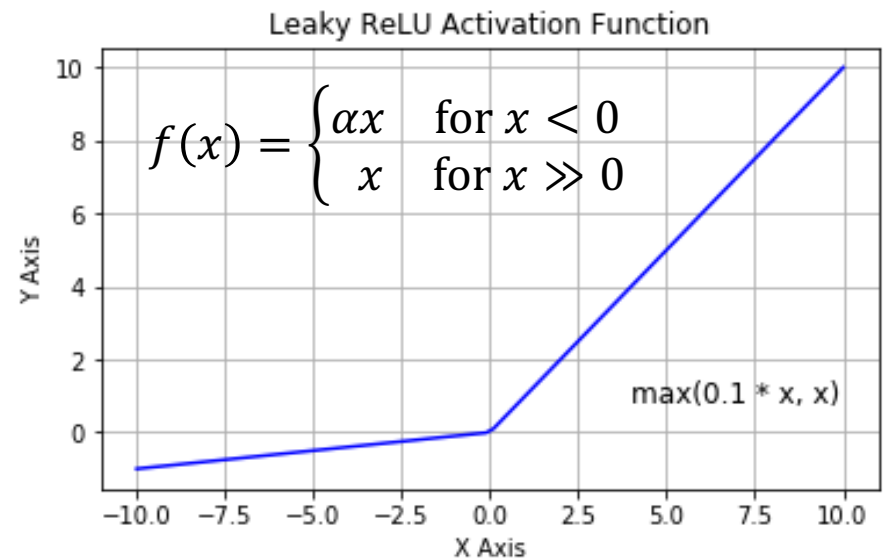

# Activation: Linear Function

*Introduction to Neural Networks*

- **Linear function** means that the output signal is proportional to the input signal to the neuron
  - If the value of the constant  $c$  is 1, it is also called **identity activation function**
  - This activation type is used in regression problems
    - E.g., the last layer can have linear activation function, in order to output a real number (and not a class membership)

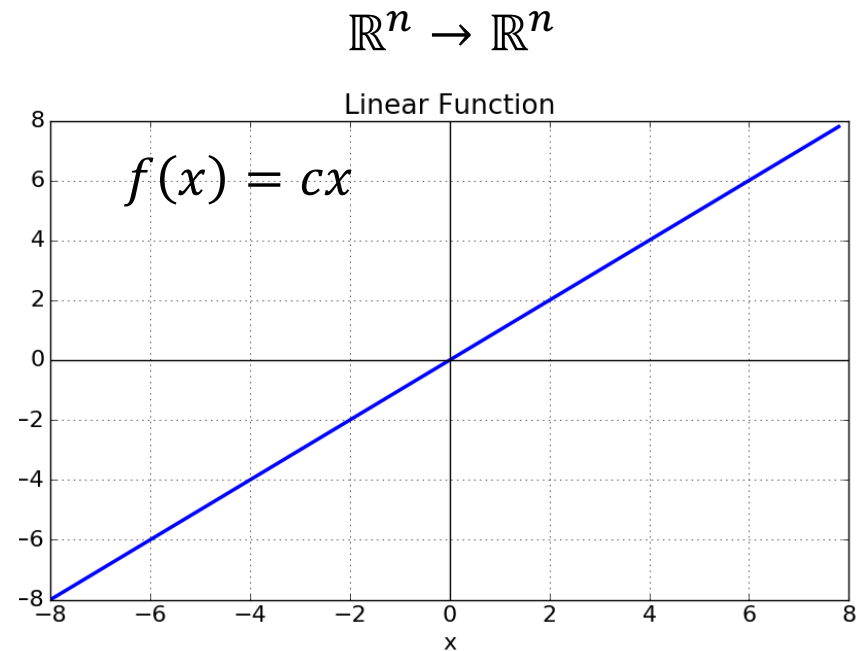

# Training NNs

## Training Neural Networks

- The network *parameters*  $\theta$  include the **weight matrices** and **bias vectors** from all layers

$$\theta = \{W^1, b^1, W^2, b^2, \dots, W^L, b^L\}$$

- Often, the model parameters  $\theta$  are referred to as **weights**
- Training a model to learn a set of parameters  $\theta$  that are optimal (according to a criterion) is one of the greatest challenges in ML

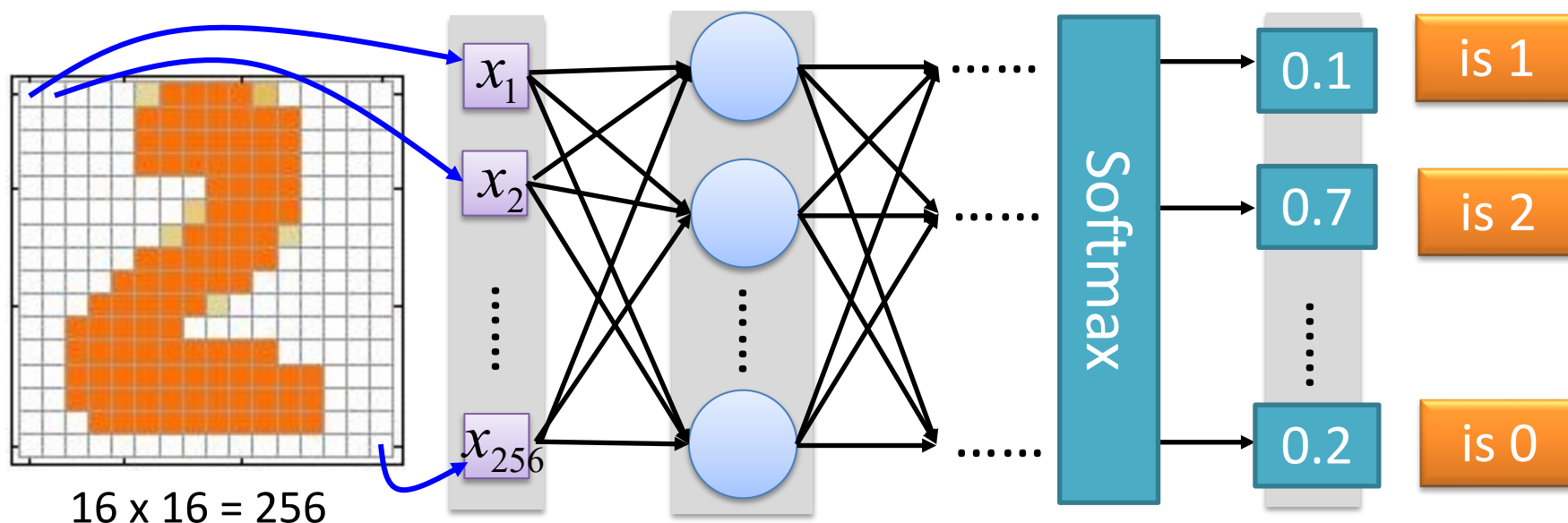

# Training NNs

## Training Neural Networks

- **Data preprocessing** - helps convergence during training
  - **Mean subtraction**, to obtain zero-centered data
    - Subtract the mean for each individual data dimension (feature)
  - **Normalization**
    - Divide each feature by its standard deviation
      - To obtain standard deviation of 1 for each data dimension (feature)
    - Or, scale the data within the range  $[0,1]$  or  $[-1, 1]$ 
      - E.g., image pixel intensities are divided by 255 to be scaled in the  $[0,1]$  range

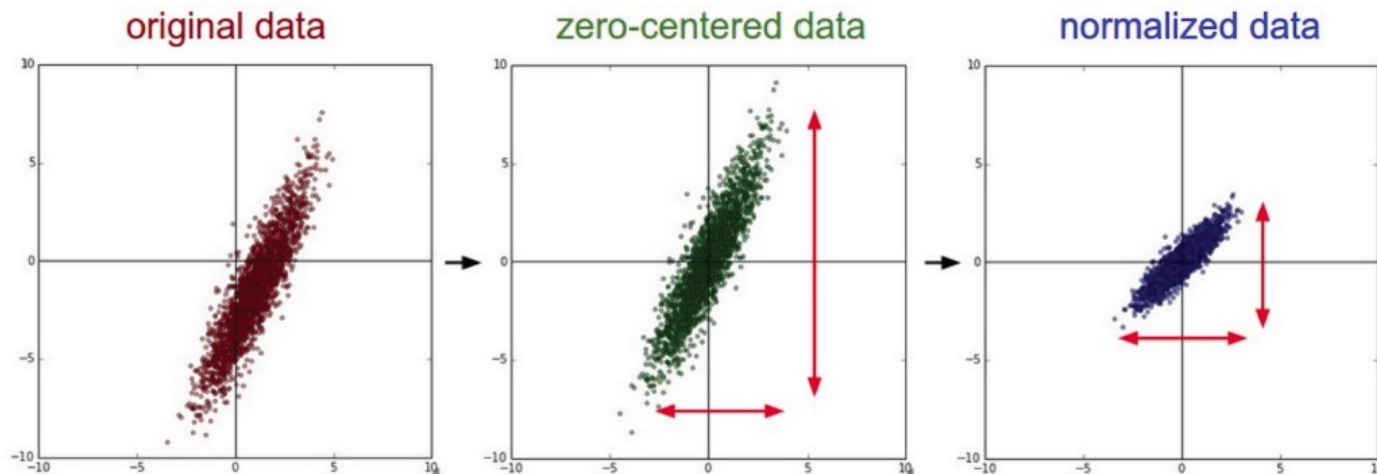

# Training NNs

## Training Neural Networks

- To train a NN, set the parameters  $\theta$  such that for a training subset of images, the corresponding elements in the predicted output have maximum values

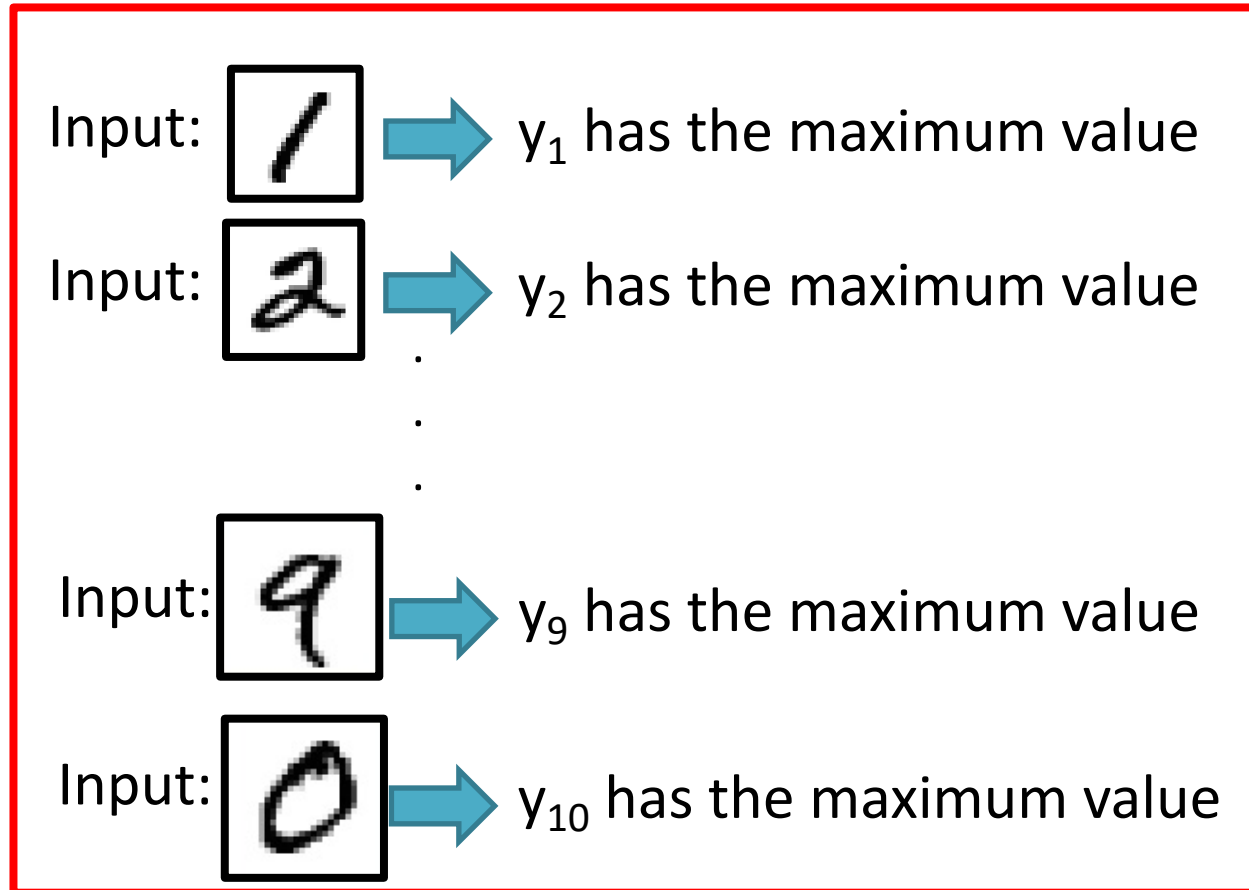

# Training NNs

## Training Neural Networks

- Define a **loss function/objective function/cost function**  $\mathcal{L}(\theta)$  that calculates the difference (error) between the model prediction and the true label
  - E.g.,  $\mathcal{L}(\theta)$  can be mean-squared error, cross-entropy, etc.

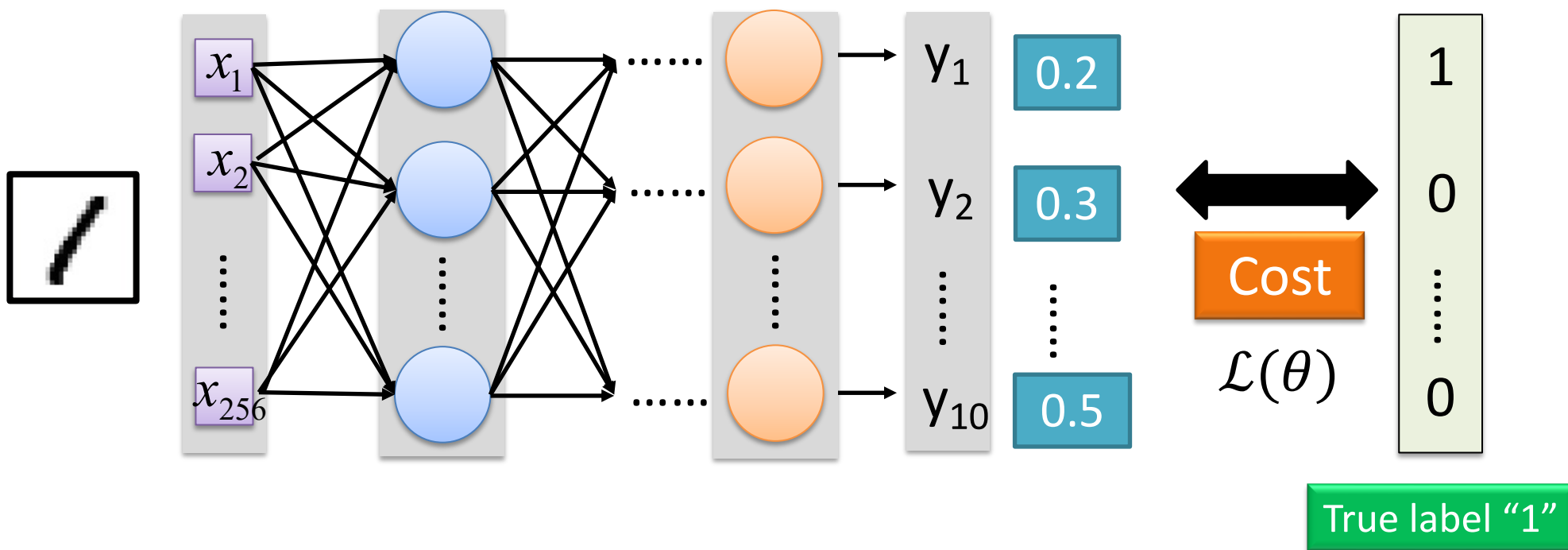



# Training NNs

## Training Neural Networks

- For a training set of  $N$  images, calculate the total loss overall all images:  $\mathcal{L}(\theta) = \sum_{n=1}^N \mathcal{L}_n(\theta)$
- Find the optimal parameters  $\theta^*$  that minimize the total loss  $\mathcal{L}(\theta)$

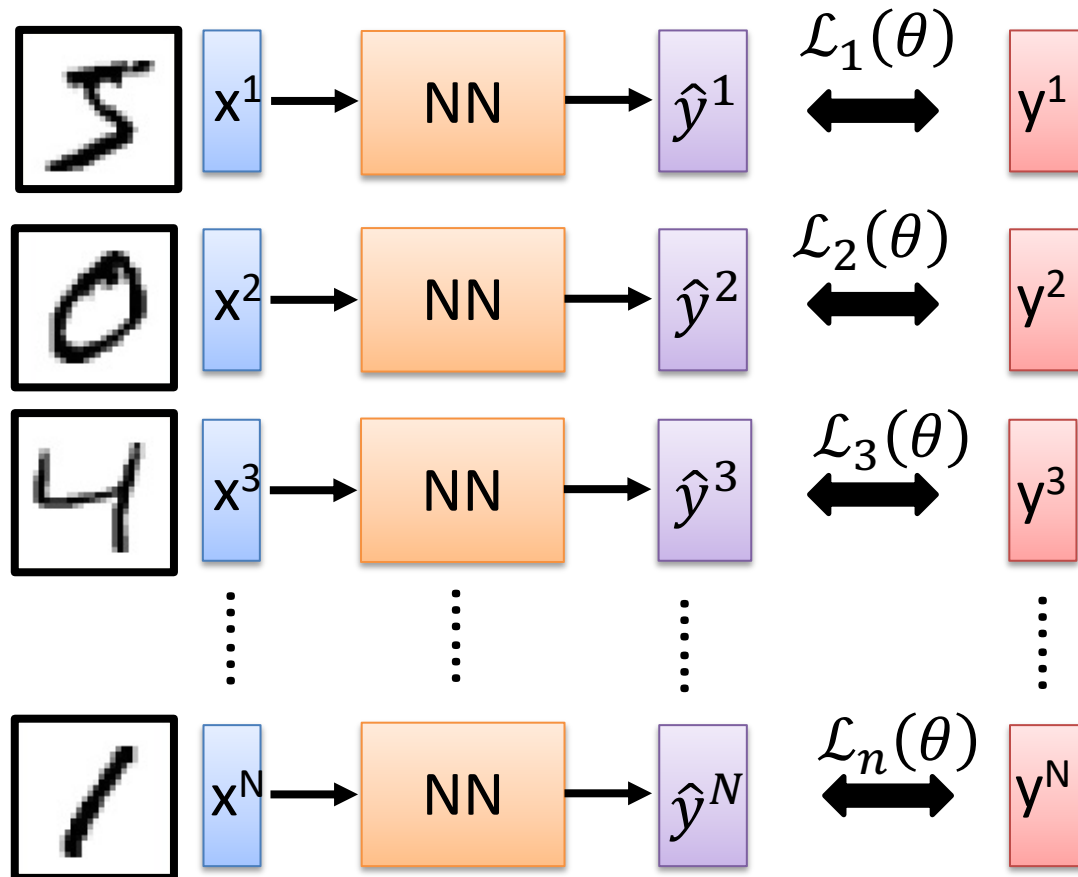

# Loss Functions

Training Neural Networks

- *Classification tasks*

**Training examples**

Pairs of  $N$  inputs  $x_i$  and ground-truth class labels  $y_i$

**Output Layer**

Softmax Activations  
[maps to a probability distribution]

$$P(y = j | \mathbf{x}) = \frac{e^{\mathbf{x}^T \mathbf{w}_j}}{\sum_{k=1}^K e^{\mathbf{x}^T \mathbf{w}_k}}$$

**Loss function**

**Cross-entropy**  $\mathcal{L}(\theta) = -\frac{1}{N} \sum_{i=1}^N \sum_{k=1}^K \left[ y_k^{(i)} \log \hat{y}_k^{(i)} + (1 - y_k^{(i)}) \log (1 - \hat{y}_k^{(i)}) \right]$

Ground-truth class labels  $y_i$  and model predicted class labels  $\hat{y}_i$

# Loss Functions

*Training Neural Networks*

- *Regression tasks*

**Training examples**

Pairs of  $N$  inputs  $x_i$  and ground-truth output values  $y_i$

**Output Layer**

Linear (Identity) or Sigmoid Activation

**Loss function**

**Mean Squared Error**  $\mathcal{L}(\theta) = \frac{1}{n} \sum_{i=1}^n (y^{(i)} - \hat{y}^{(i)})^2$

**Mean Absolute Error**  $\mathcal{L}(\theta) = \frac{1}{n} \sum_{i=1}^n |y^{(i)} - \hat{y}^{(i)}|$

# Training NNs

## Training Neural Networks

- Optimizing the loss function  $\mathcal{L}(\theta)$ 
  - Almost all DL models these days are trained with a variant of the *gradient descent* (GD) algorithm
  - GD applies iterative refinement of the network **parameters  $\theta$**
  - GD uses the opposite direction of the **gradient** of the loss with respect to the NN parameters (i.e.,  $\nabla\mathcal{L}(\theta) = [\partial\mathcal{L}/\partial\theta_i]$ ) for updating  $\theta$ 
    - The gradient of the loss function  $\nabla\mathcal{L}(\theta)$  gives the direction of fastest increase of the loss function  $\mathcal{L}(\theta)$  when the parameters  $\theta$  are changed

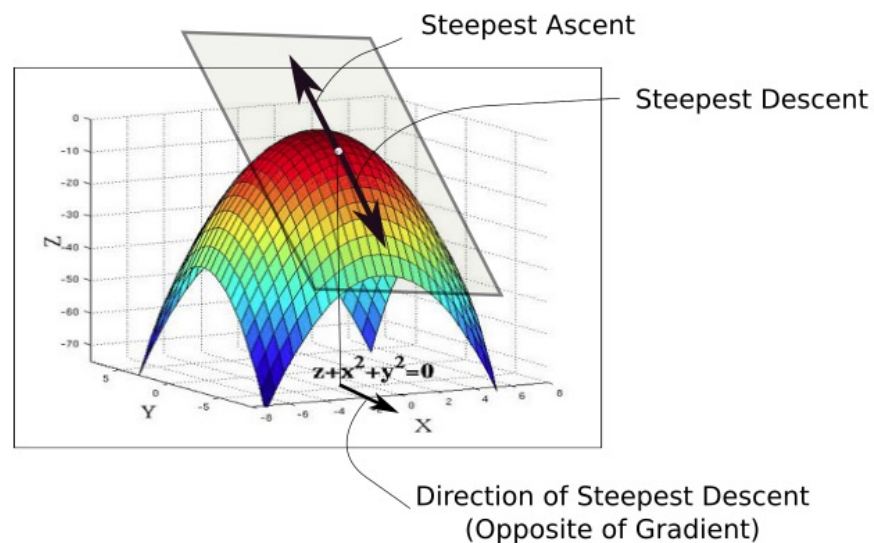
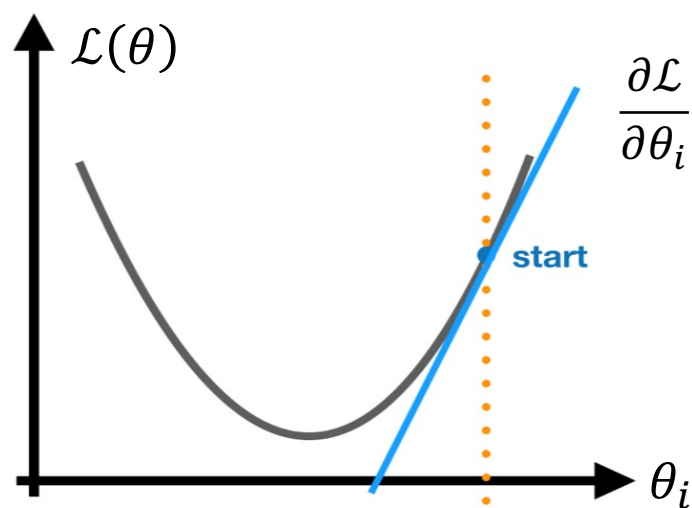

# Gradient Descent Algorithm

*Training Neural Networks*

- Steps in the *gradient descent algorithm*:
  1. Randomly initialize the model parameters,  $\theta^0$
  2. Compute the gradient of the loss function at the initial parameters  $\theta^0$ :  $\nabla\mathcal{L}(\theta^0)$
  3. Update the parameters as:  $\theta^{new} = \theta^0 - \alpha\nabla\mathcal{L}(\theta^0)$ 
    - Where  $\alpha$  is the learning rate
  4. Go to step 2 and repeat (until a terminating criterion is reached)

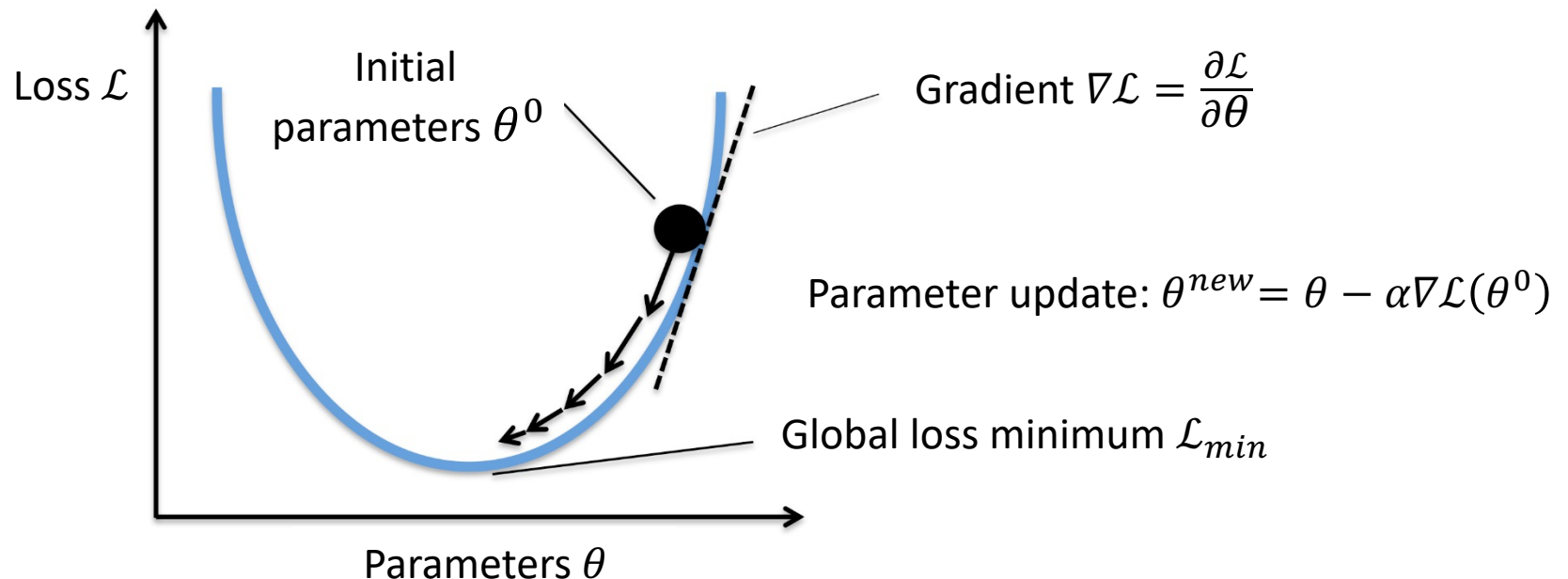

# Gradient Descent Algorithm

Training Neural Networks

- Example: a NN with only 2 parameters  $w_1$  and  $w_2$ , i.e.,  $\theta = \{w_1, w_2\}$ 
  - The different colors represent the values of the loss (minimum loss  $\theta^*$  is  $\approx 1.3$ )

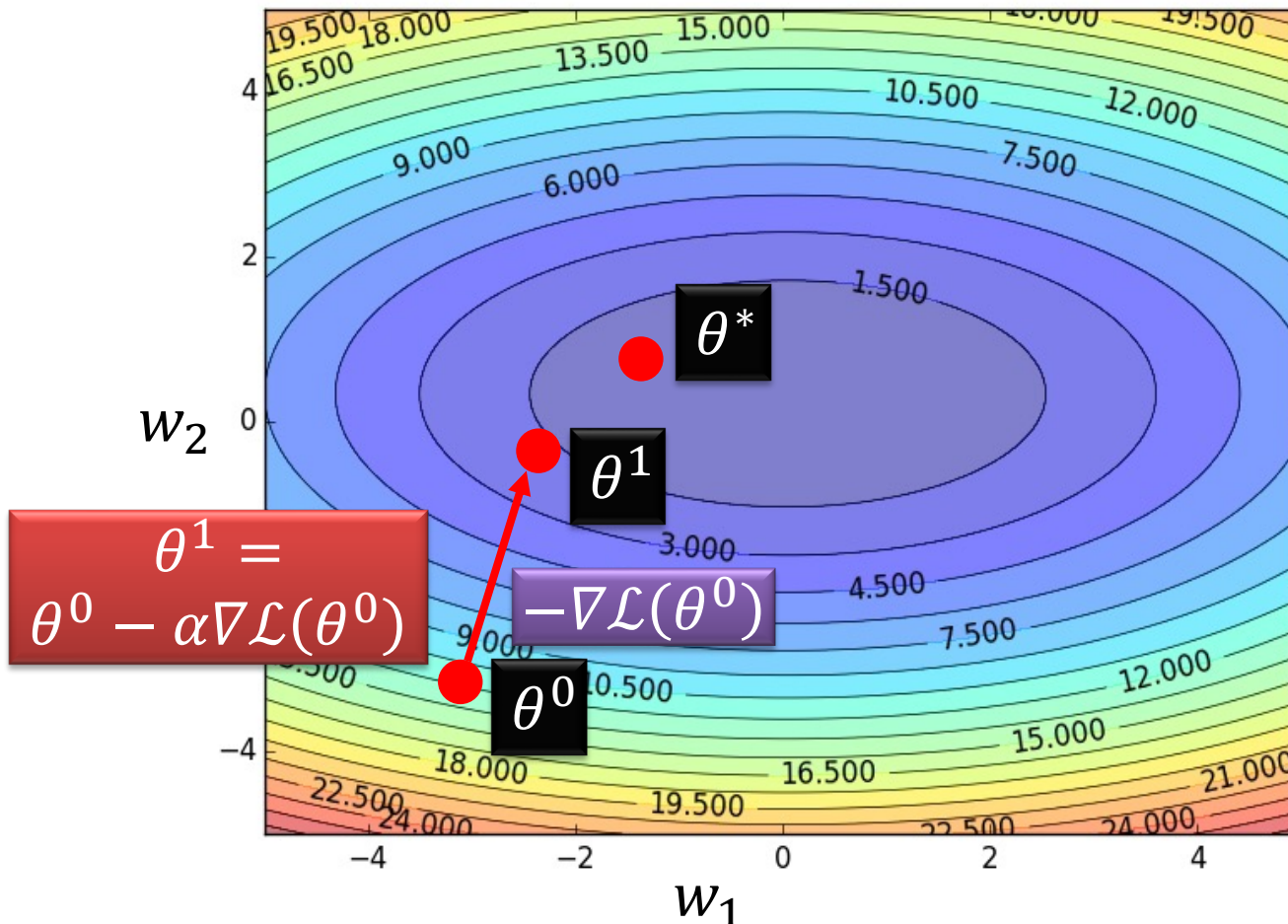

1. Randomly pick a starting point  $\theta^0$
2. Compute the gradient at  $\theta^0$ ,  $\nabla \mathcal{L}(\theta^0)$
3. Times the learning rate  $\eta$ , and update  $\theta$ ,  
 $\theta^{new} = \theta^0 - \alpha \nabla \mathcal{L}(\theta^0)$
4. Go to step 2, repeat

$$\nabla \mathcal{L}(\theta^0) = \begin{bmatrix} \partial \mathcal{L}(\theta^0) / \partial w_1 \\ \partial \mathcal{L}(\theta^0) / \partial w_2 \end{bmatrix}$$

# Gradient Descent Algorithm

Training Neural Networks

- Example (contd.)

Eventually, we would reach a minimum .....

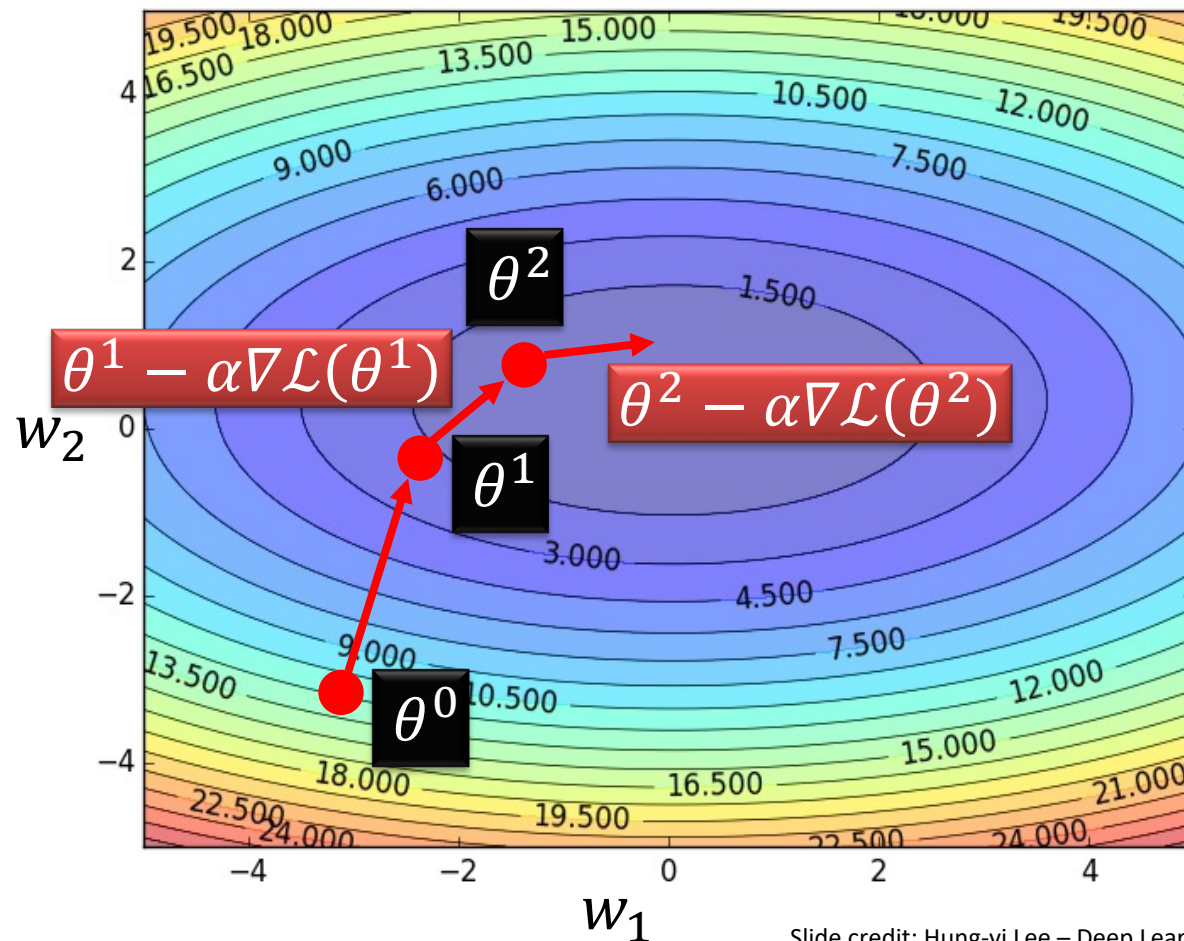

2. Compute the gradient at  $\theta^{old}$ ,  $\nabla \mathcal{L}(\theta^{old})$

3. Times the learning rate  $\eta$ , and update  $\theta$ ,  
$$\theta^{new} = \theta^{old} - \alpha \nabla \mathcal{L}(\theta^{old})$$

4. Go to step 2, repeat

# Gradient Descent Algorithm

*Training Neural Networks*

- Gradient descent algorithm stops when a **local minimum** of the loss surface is reached
  - GD does not guarantee reaching a **global minimum**
  - However, empirical evidence suggests that GD works well for NNs

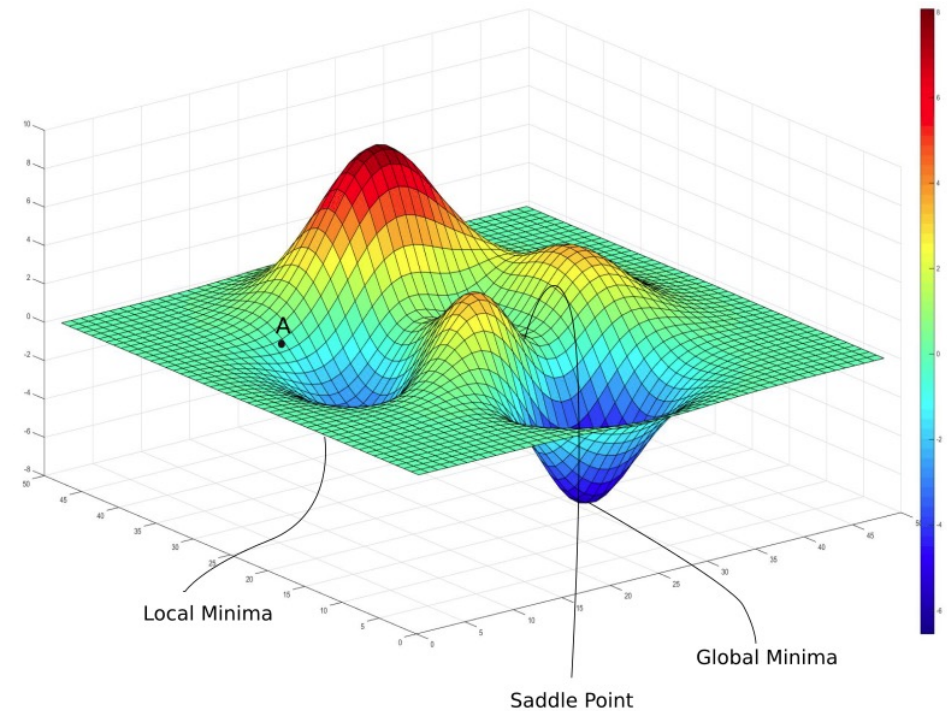
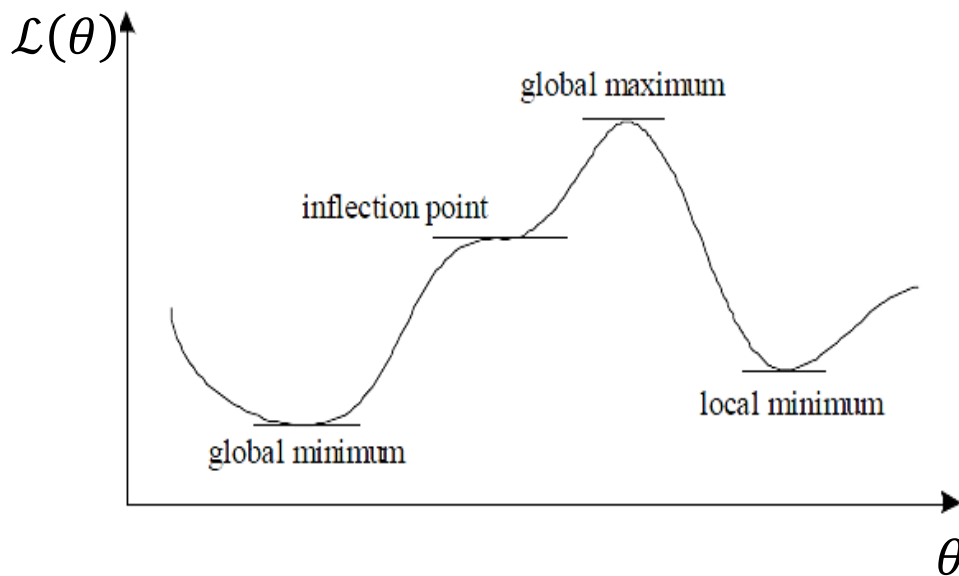



# Gradient Descent Algorithm

## Training Neural Networks

- For most tasks, the **loss surface**  $\mathcal{L}(\theta)$  is highly complex (and non-convex)
- Random initialization in NNs results in different initial parameters  $\theta^0$  every time the NN is trained
  - Gradient descent may reach different minima at every run
  - Therefore, NN will produce different predicted outputs
- In addition, currently we don't have algorithms that guarantee reaching a **global minimum** for an arbitrary loss function

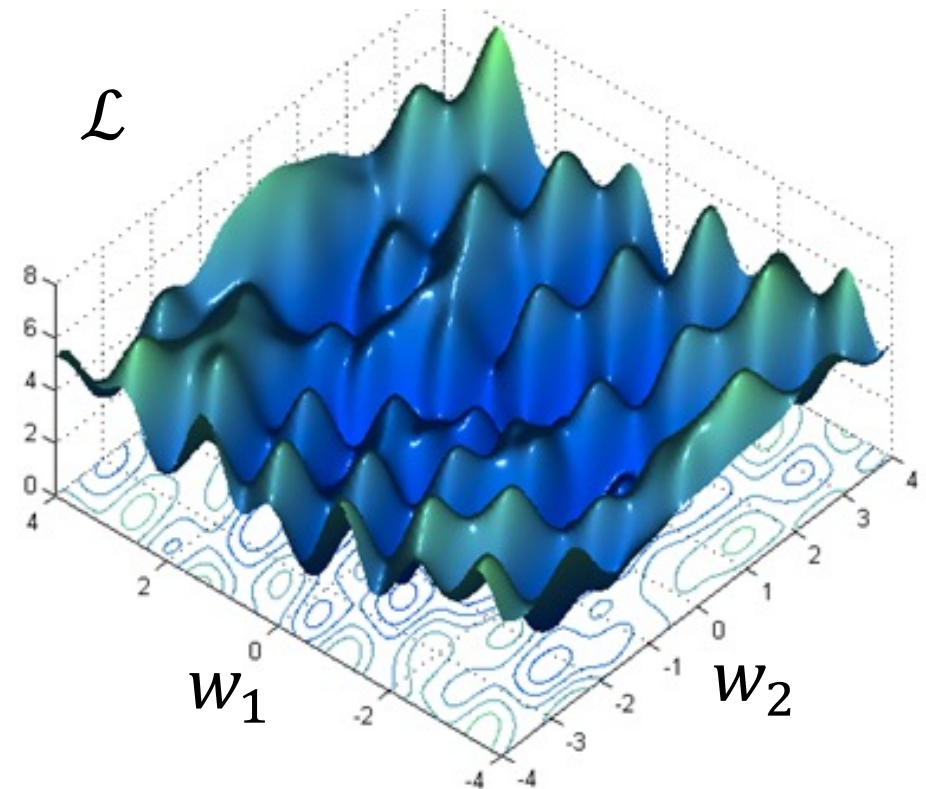

# Backpropagation

## *Training Neural Networks*

- Modern NNs employ the *backpropagation* method for calculating the gradients of the loss function  $\nabla\mathcal{L}(\theta) = \partial\mathcal{L}/\partial\theta_i$ 
  - Backpropagation is short for “backward propagation”
- For training NNs, *forward propagation* (forward pass) refers to passing the inputs  $x$  through the hidden layers to obtain the model outputs (predictions)  $y$ 
  - The loss  $\mathcal{L}(y, \hat{y})$  function is then calculated
  - *Backpropagation* traverses the network in reverse order, from the outputs  $y$  backward toward the inputs  $x$  to calculate the gradients of the loss  $\nabla\mathcal{L}(\theta)$
  - The chain rule is used for calculating the partial derivatives of the loss function with respect to the parameters  $\theta$  in the different layers in the network
- Each update of the model parameters  $\theta$  during training takes one forward and one backward pass (e.g., of a batch of inputs)
- Automatic calculation of the gradients (*automatic differentiation*) is available in all current deep learning libraries
  - It significantly simplifies the implementation of deep learning algorithms, since it obviates deriving the partial derivatives of the loss function by hand

# Mini-batch Gradient Descent

*Training Neural Networks*

- It is wasteful to compute the loss over the **entire training dataset** to perform a single parameter update for large datasets
  - E.g., ImageNet has 14M images
  - Therefore, GD (a.k.a. vanilla GD) is almost always replaced with mini-batch GD
- *Mini-batch gradient descent*
  - Approach:
    - Compute the loss  $\mathcal{L}(\theta)$  on a mini-batch of images, update the parameters  $\theta$ , and repeat until all images are used
    - At the next epoch, shuffle the training data, and repeat the above process
  - Mini-batch GD results in much faster training
  - Typical mini-batch size: 32 to 256 images
  - It works because the gradient from a mini-batch is a good approximation of the gradient from the entire training set

# Stochastic Gradient Descent

*Training Neural Networks*

- *Stochastic gradient descent*
  - SGD uses mini-batches that consist of a **single input example**
    - E.g., one image mini-batch
  - Although this method is very fast, it may cause significant fluctuations in the loss function
    - Therefore, it is less commonly used, and mini-batch GD is preferred
  - In most DL libraries, SGD typically means a mini-batch GD (with an option to add momentum)

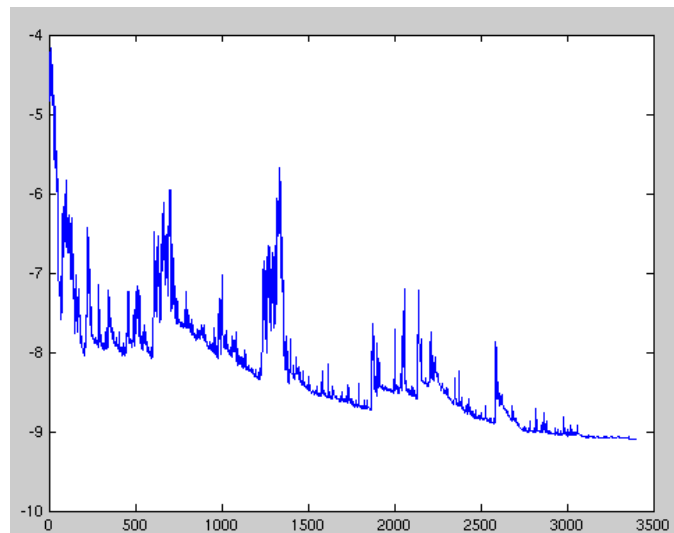

# Problems with Gradient Descent

Training Neural Networks

- Besides the local minima problem, the GD algorithm can be very slow at **plateaus**, and it can get stuck at **saddle points**

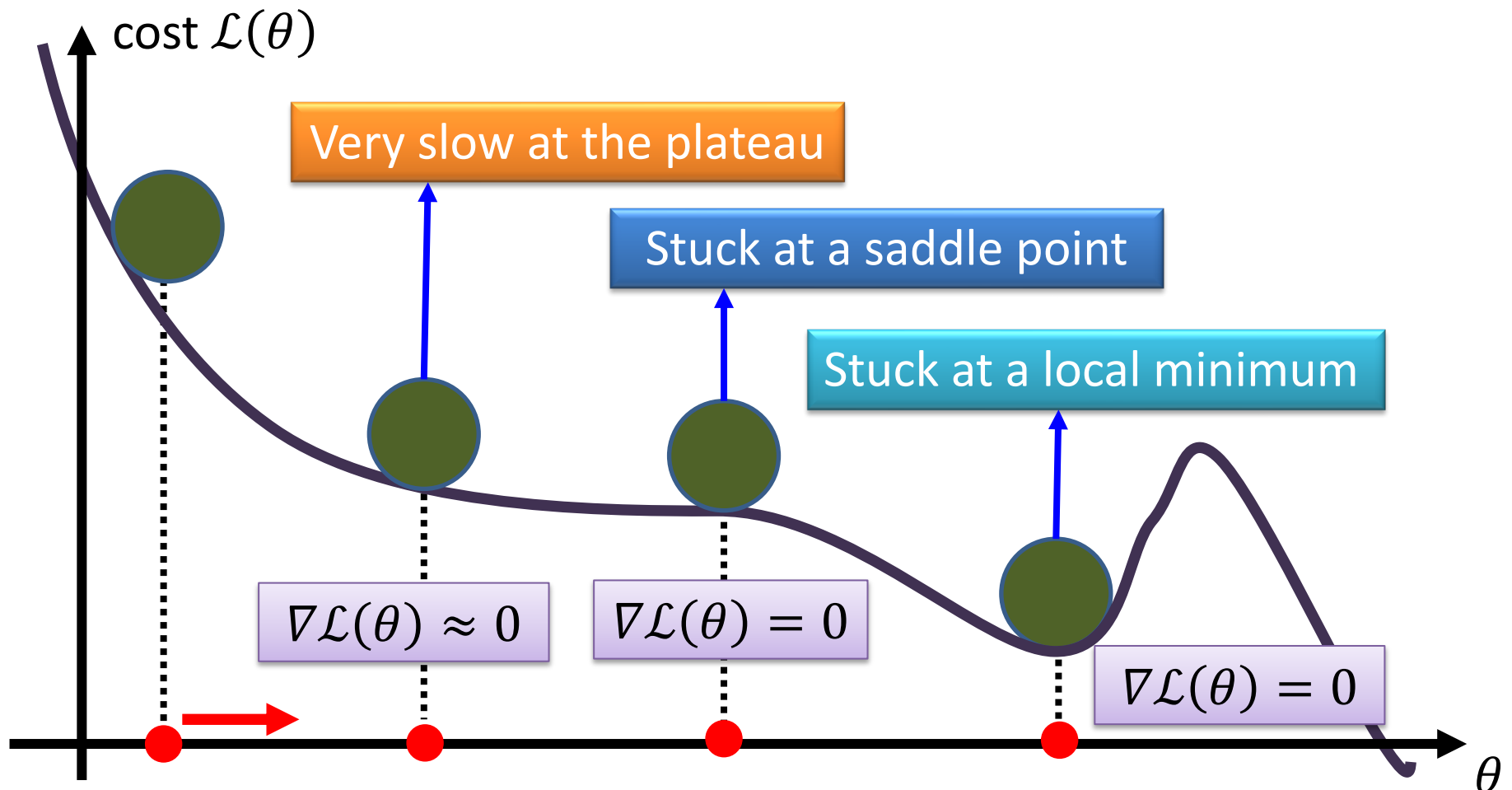

# Gradient Descent with Momentum

Training Neural Networks

- *Gradient descent with momentum* uses the momentum of the gradient for parameter optimization

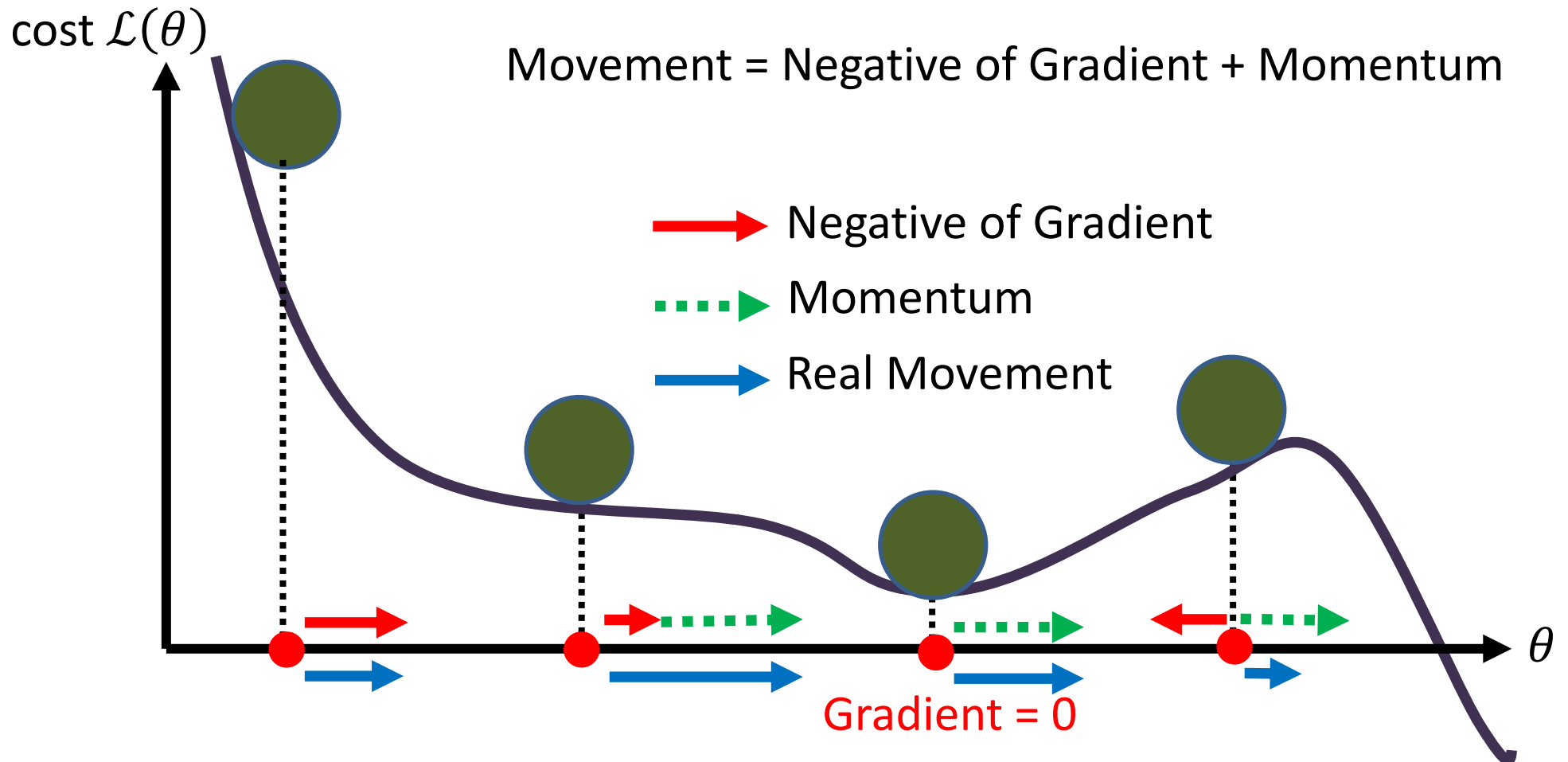

# Gradient Descent with Momentum

*Training Neural Networks*

- Parameters update in **GD with momentum** at iteration  $t$ :  $\theta^t = \theta^{t-1} - V^t$ 
  - Where:  $V^t = \beta V^{t-1} + \alpha \nabla \mathcal{L}(\theta^{t-1})$
  - I.e.,  $\theta^t = \theta^{t-1} - \alpha \nabla \mathcal{L}(\theta^{t-1}) - \beta V^{t-1}$
- Compare to vanilla GD:  $\theta^t = \theta^{t-1} - \alpha \nabla \mathcal{L}(\theta^{t-1})$ 
  - Where  $\theta^{t-1}$  are the parameters from the previous iteration  $t - 1$
- The term  $V^t$  is called **momentum**
  - This term accumulates the gradients from the past several steps, i.e.,
$$\begin{aligned} V^t &= \beta V^{t-1} + \alpha \nabla \mathcal{L}(\theta^{t-1}) \\ &= \beta(\beta V^{t-2} + \alpha \nabla \mathcal{L}(\theta^{t-2})) + \alpha \nabla \mathcal{L}(\theta^{t-1}) \\ &= \beta^2 V^{t-2} + \beta \alpha \nabla \mathcal{L}(\theta^{t-2}) + \alpha \nabla \mathcal{L}(\theta^{t-1}) \\ &= \beta^3 V^{t-3} + \beta^2 \alpha \nabla \mathcal{L}(\theta^{t-3}) + \beta \alpha \nabla \mathcal{L}(\theta^{t-2}) + \alpha \nabla \mathcal{L}(\theta^{t-1}) \end{aligned}$$
  - This term is analogous to a momentum of a heavy ball rolling down the hill
- The parameter  $\beta$  is referred to as a **coefficient of momentum**
  - A typical value of the parameter  $\beta$  is 0.9
- This method updates the parameters  $\theta$  in the direction of the weighted average of the past gradients

# Nesterov Accelerated Momentum

Training Neural Networks

- **Gradient descent with Nesterov accelerated momentum**
  - Parameter update:  $\theta^t = \theta^{t-1} - V^t$ 
    - Where:  $V^t = \beta V^{t-1} + \alpha \nabla \mathcal{L}(\theta^{t-1} + \beta V^{t-1})$
  - The term  $\theta^{t-1} + \beta V^{t-1}$  allows to predict the position of the parameters in the next step (i.e.,  $\theta^t \approx \theta^{t-1} + \beta V^{t-1}$ )
  - The gradient is calculated with respect to the approximate future position of the parameters in the next iteration,  $\theta^t$ , calculated at iteration  $t - 1$

GD with momentum

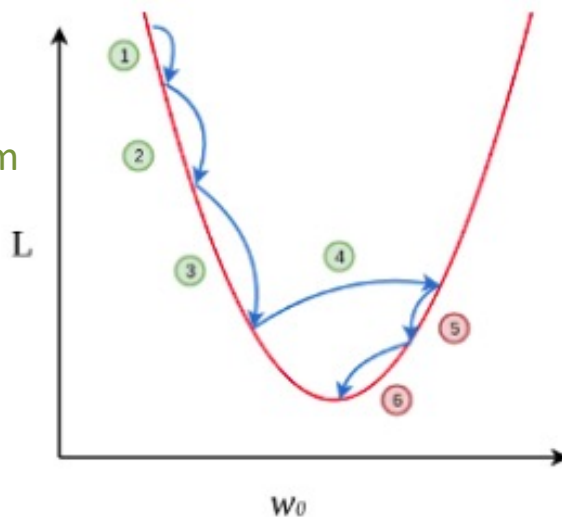

GD with Nesterov momentum

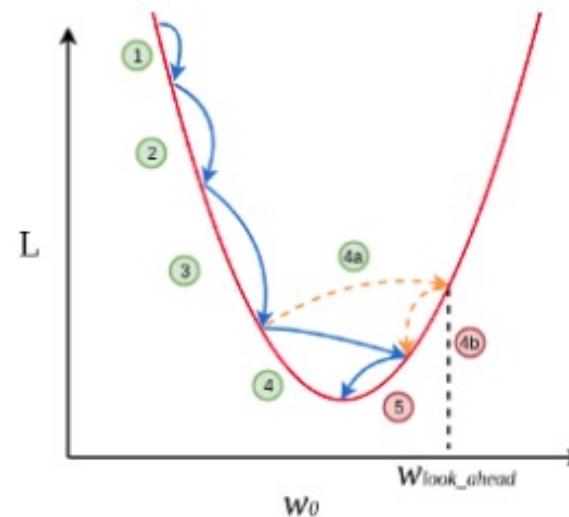



# Adam

Training Neural Networks

- **Adaptive Moment Estimation (Adam)**
  - Adam combines insights from the momentum optimizers that accumulate the values of past gradients, and it also introduces new terms based on the second moment of the gradient
    - Similar to GD with momentum, Adam computes a **weighted average of past gradients** (**first moment** of the gradient), i.e.,  $V^t = \beta_1 V^{t-1} + (1 - \beta_1) \nabla \mathcal{L}(\theta^{t-1})$
    - Adam also computes a **weighted average of past squared gradients** (**second moment** of the gradient), i.e.,  $U^t = \beta_2 U^{t-1} + (1 - \beta_2) (\nabla \mathcal{L}(\theta^{t-1}))^2$
  - The parameter update is:  $\theta^t = \theta^{t-1} - \alpha \frac{\hat{v}^t}{\sqrt{\hat{u}^t + \epsilon}}$ 
    - Where:  $\hat{v}^t = \frac{V^t}{1 - \beta_1}$  and  $\hat{u}^t = \frac{U^t}{1 - \beta_2}$
    - The proposed default values are  $\beta_1 = 0.9$ ,  $\beta_2 = 0.999$ , and  $\epsilon = 10^{-8}$
- Other commonly used optimization methods include:
  - Adagrad, Adadelata, RMSprop, Nadam, etc.
  - Most commonly used optimizers nowadays are Adam and SGD with momentum

# Learning Rate

*Training Neural Networks*

- *Learning rate*

- The gradient tells us the direction in which the loss has the steepest rate of increase, but it does not tell us how far along the opposite direction we should step
- Choosing the learning rate (also called the **step size**) is one of the most important hyper-parameter settings for NN training

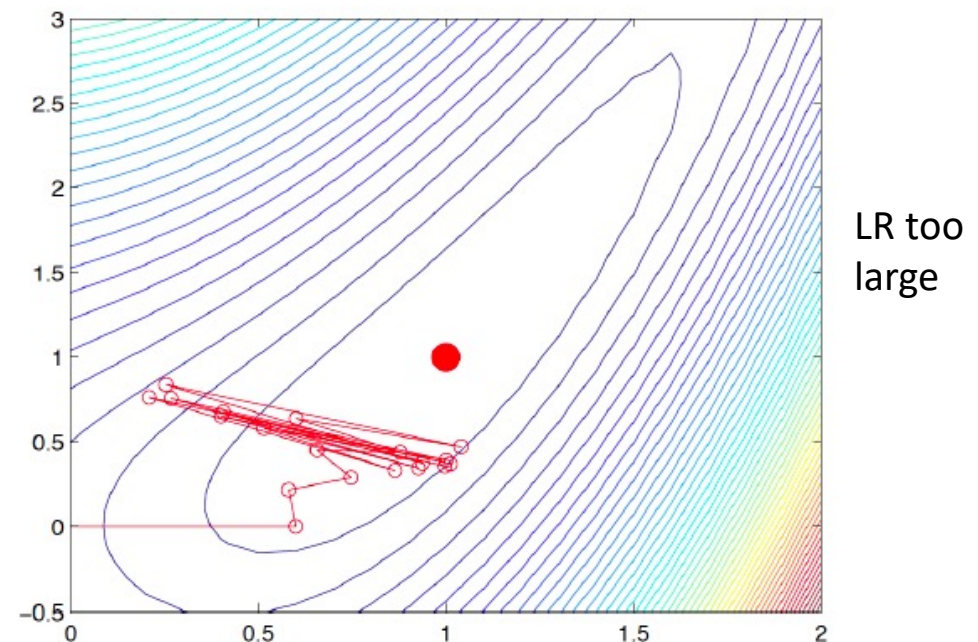
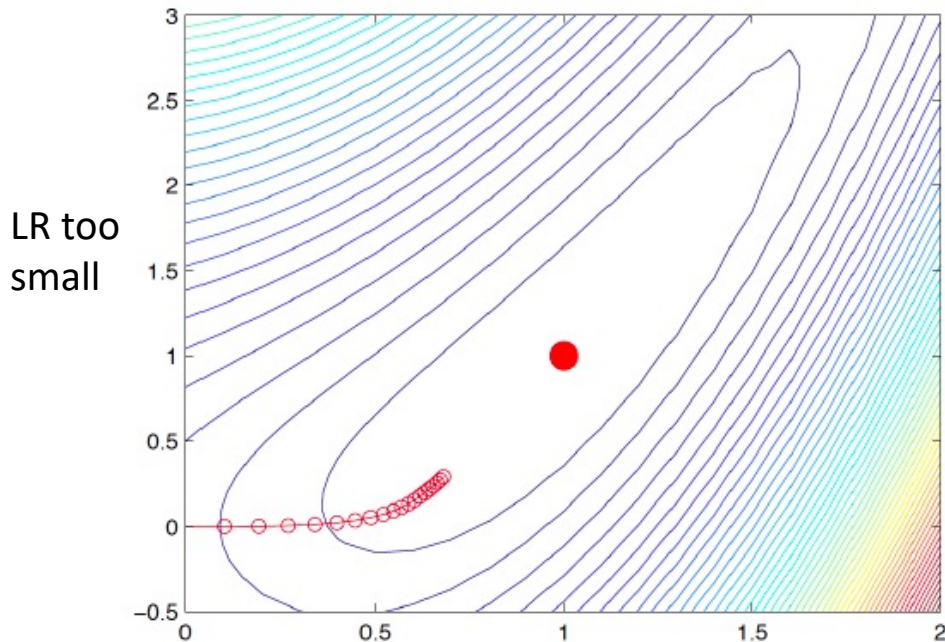

# Learning Rate

## *Training Neural Networks*

- Training loss for different learning rates
  - High learning rate: the loss increases or plateaus too quickly
  - Low learning rate: the loss decreases too slowly (takes many epochs to reach a solution)

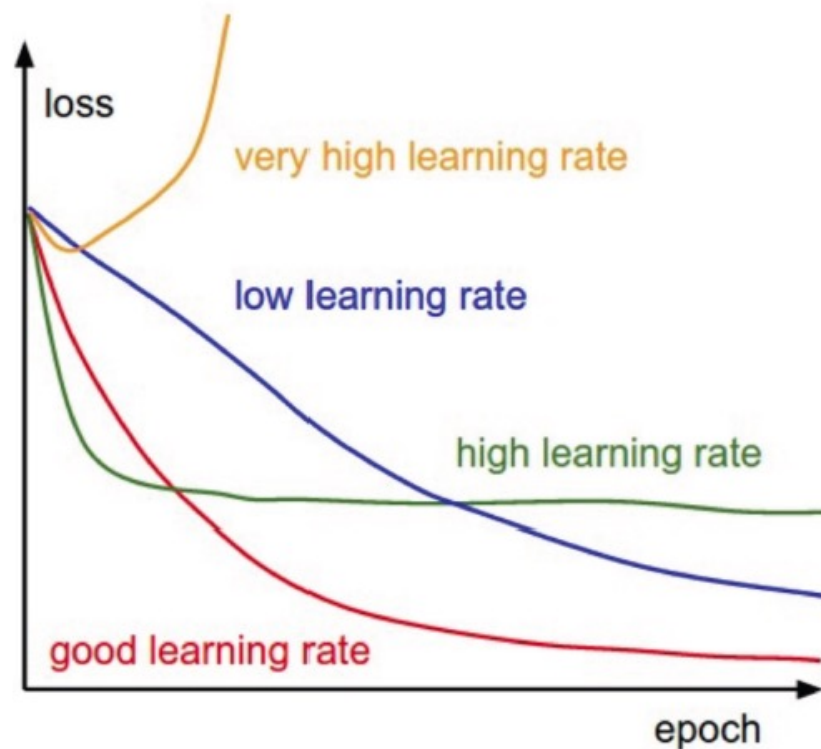

# Learning Rate Scheduling

Training Neural Networks

- **Learning rate scheduling** is applied to change the values of the learning rate during the training
  - **Annealing** is reducing the learning rate over time (a.k.a. learning rate decay)
    - Approach 1: reduce the learning rate by some factor **every few epochs**
      - Typical values: reduce the learning rate by a half every 5 epochs, or divide by 10 every 20 epochs
    - Approach 2: **exponential** or **cosine decay** gradually reduce the learning rate over time
    - Approach 3: reduce the learning rate by a constant (e.g., by half) whenever the **validation loss stops improving**
      - In TensorFlow: `tf.keras.callbacks.ReduceLROnPleateau()`
        - » Monitor: validation loss, factor: 0.1 (i.e., divide by 10), patience: 10 (how many epochs to wait before applying it), Minimum learning rate: 1e-6 (when to stop)
  - **Warmup** is gradually increasing the learning rate initially, and afterward let it cool down until the end of the training

Exponential decay

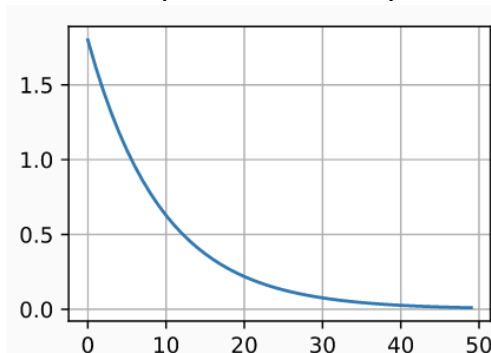

Cosine decay

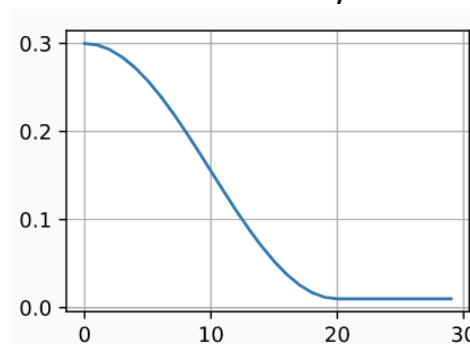

Warmup

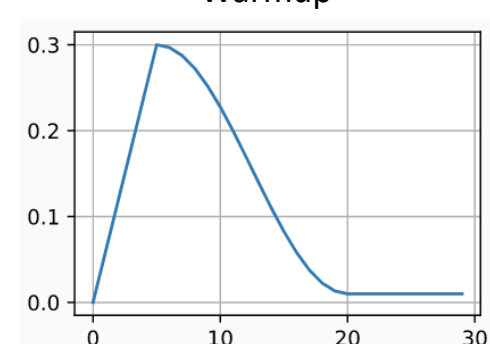

# Vanishing Gradient Problem

## Training Neural Networks

- In some cases, during training, the gradients can become either very small (vanishing gradients) or very large (exploding gradients)
  - They result in very small or very large update of the parameters
  - Solutions: change learning rate, ReLU activations, regularization, LSTM units in RNNs

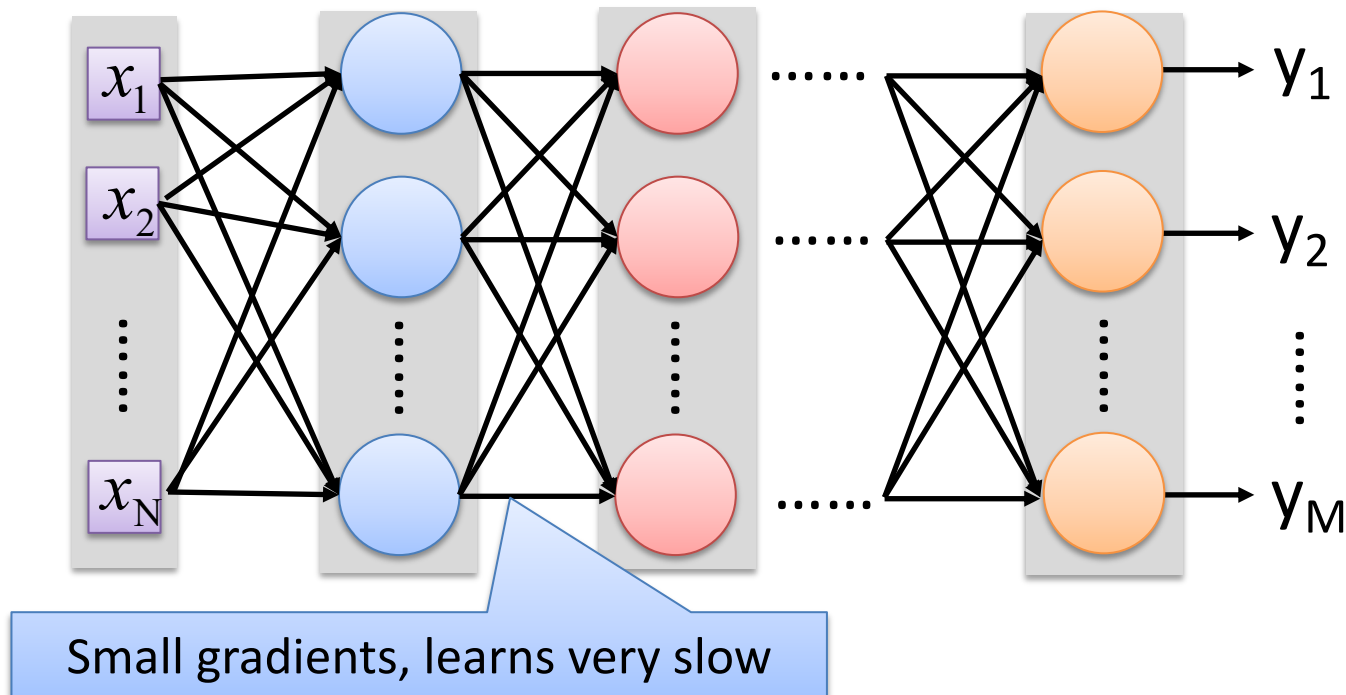

# Generalization

## Generalization

- **Underfitting**

- The model is too “simple” to represent all the relevant class characteristics
- E.g., model with too few parameters
- Produces high error on the training set and high error on the validation set

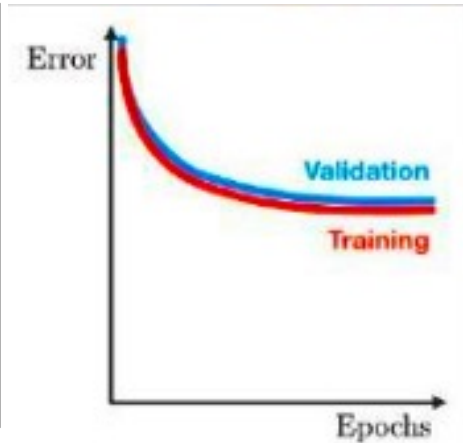
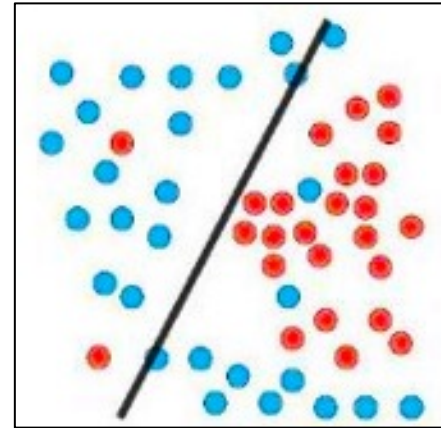

- **Overfitting**

- The model is too “complex” and fits irrelevant characteristics (noise) in the data
- E.g., model with too many parameters
- Produces low error on the training error and high error on the validation set

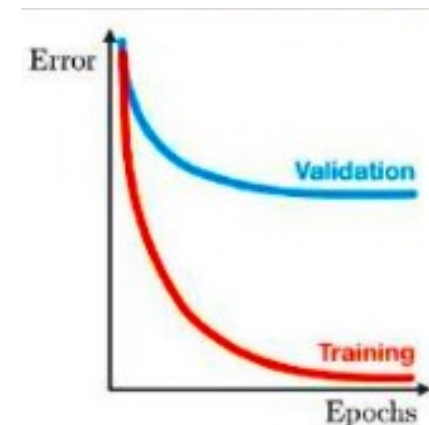
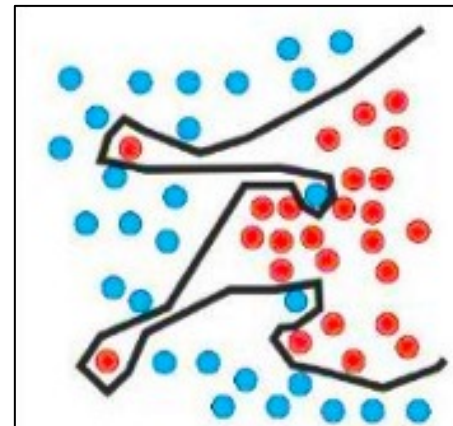

# Overfitting

## Generalization

- Overfitting – a model with high capacity fits the noise in the data instead of the underlying relationship

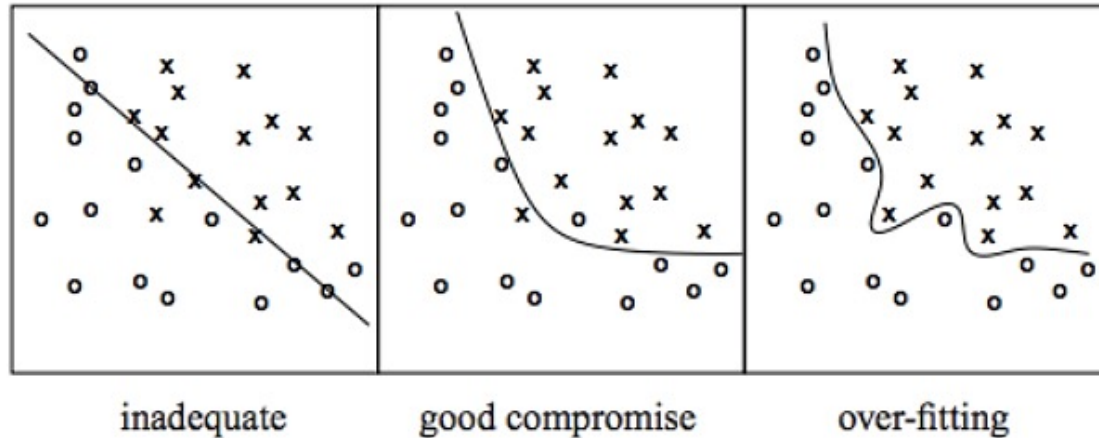

- The model may fit the training data very well, but fails to **generalize** to new examples (test or validation data)

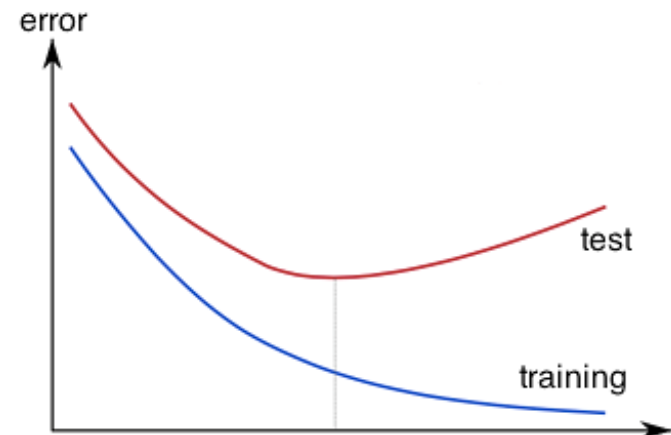

# Regularization: Weight Decay

## Regularization

- $\ell_2$  weight decay

- A regularization term that penalizes large weights is added to the loss function

$$\mathcal{L}_{reg}(\theta) = \underbrace{\mathcal{L}(\theta)}_{\text{Data loss}} + \underbrace{\lambda \sum_k \theta_k^2}_{\text{Regularization loss}}$$

- For every weight in the network, we add the regularization term to the loss value
  - During gradient descent parameter update, every weight is decayed linearly toward zero
- The **weight decay coefficient**  $\lambda$  determines how dominant the regularization is during the gradient computation



# Regularization: Weight Decay

## *Regularization*

- Effect of the decay coefficient  $\lambda$ 
  - Large weight decay coefficient  $\rightarrow$  penalty for weights with large values

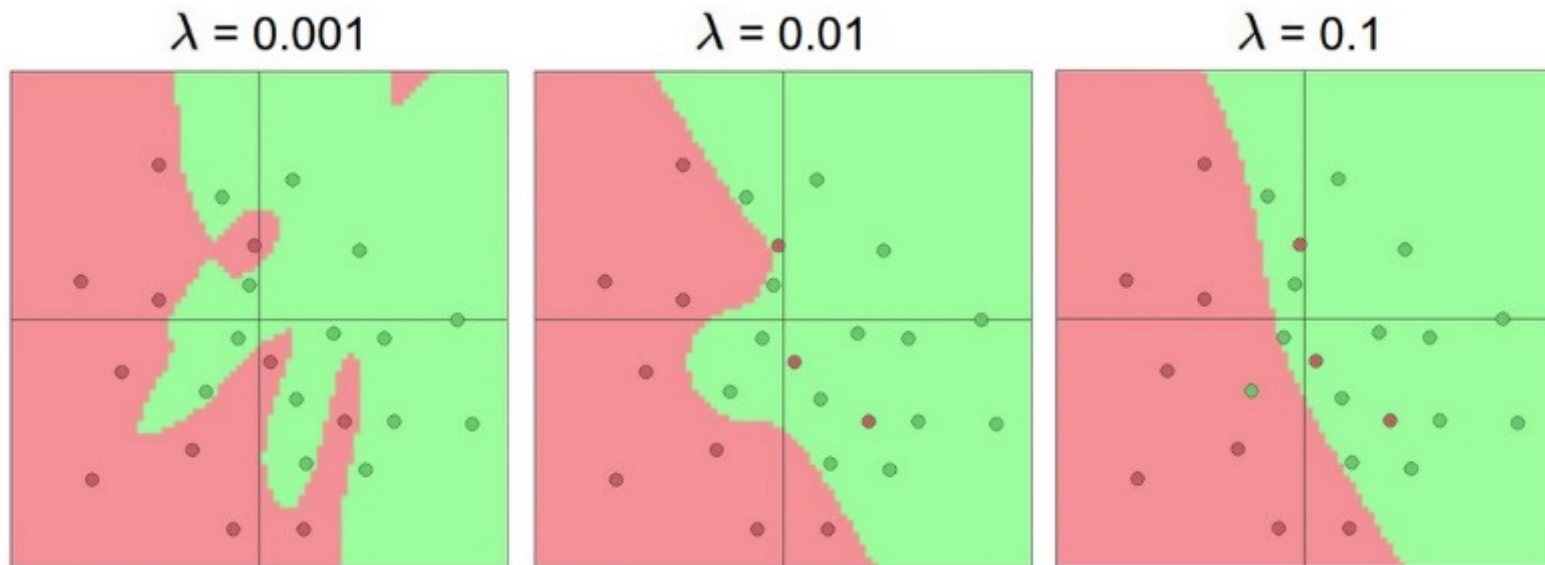

# Regularization: Weight Decay

*Regularization*

- $\ell_1$  weight decay
  - The regularization term is based on the  $\ell_1$  norm of the weights

$$\mathcal{L}_{reg}(\theta) = \mathcal{L}(\theta) + \lambda \sum_k |\theta_k|$$

- $\ell_1$  weight decay is less common with NN
  - Often performs worse than  $\ell_2$  weight decay
- It is also possible to combine  $\ell_1$  and  $\ell_2$  regularization
  - Called **elastic net regularization**

$$\mathcal{L}_{reg}(\theta) = \mathcal{L}(\theta) + \lambda_1 \sum_k |\theta_k| + \lambda_2 \sum_k \theta_k^2$$

# Regularization: Dropout

## Regularization

- **Dropout**

- Randomly drop units (along with their connections) during training
- Each unit is retained with a fixed **dropout rate  $p$** , independent of other units
- The hyper-parameter  $p$  needs to be chosen (tuned)
  - Often, between 20% and 50% of the units are dropped

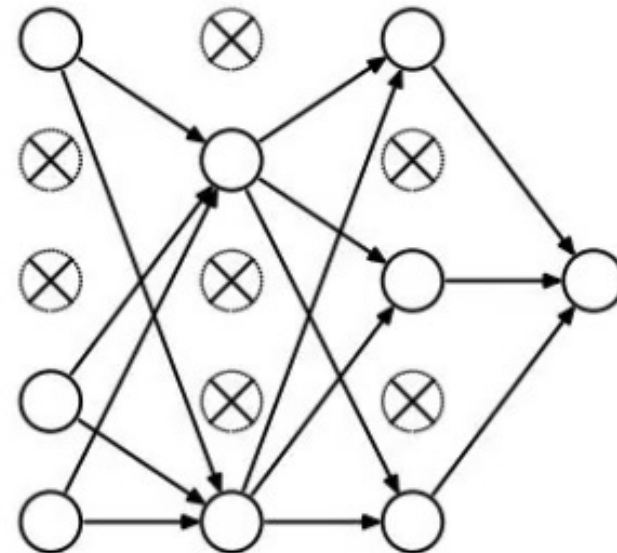
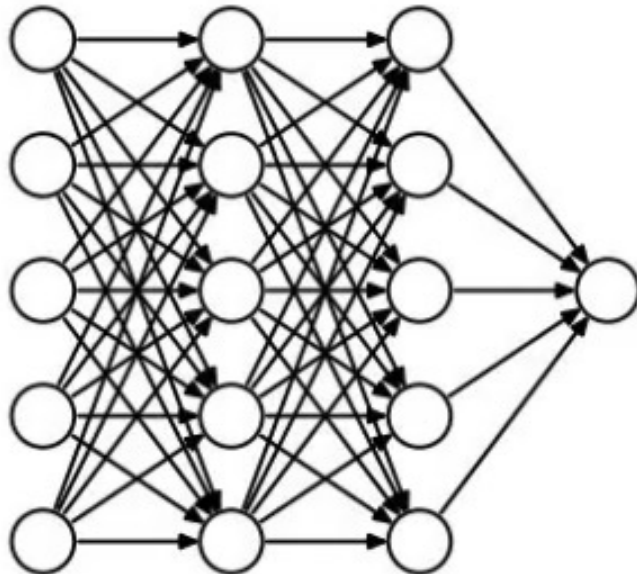

# Regularization: Dropout

## Regularization

- Dropout is a kind of ensemble learning
  - Using one mini-batch to train one network with a slightly different architecture

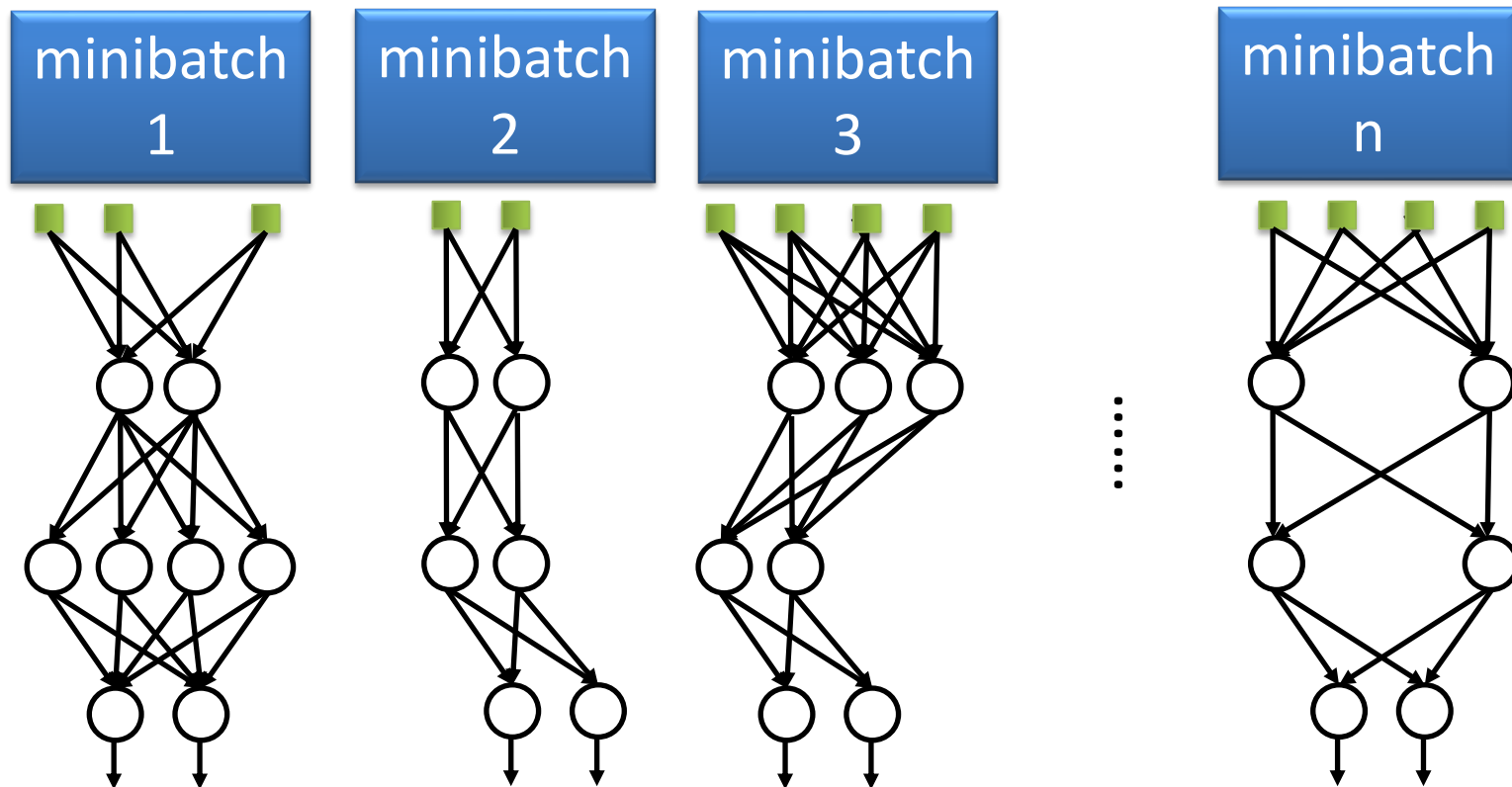

# Regularization: Early Stopping

## Regularization

- **Early-stopping**

- During model training, use a **validation set**
  - E.g., validation/train ratio of about 25% to 75%
- Stop when the validation accuracy (or loss) has not improved after  $n$  epochs
  - The parameter  $n$  is called **patience**

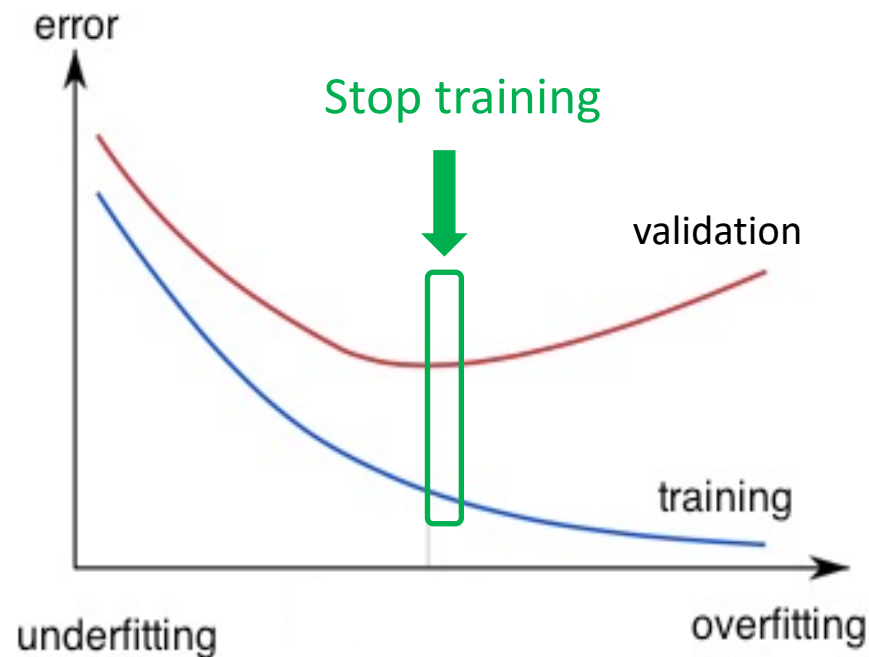

# Batch Normalization

## *Regularization*

- **Batch normalization layers** act similar to the data preprocessing steps mentioned earlier
  - They calculate the mean  $\mu$  and variance  $\sigma$  of a batch of input data, and normalize the data  $x$  to a zero mean and unit variance
  - I.e.,  $\hat{x} = \frac{x - \mu}{\sigma}$
- **BatchNorm layers** alleviate the problems of proper initialization of the parameters and hyper-parameters
  - Result in faster convergence training, allow larger learning rates
  - Reduce the internal covariate shift
- BatchNorm layers are inserted immediately after convolutional layers or fully-connected layers, and before activation layers
  - They are very common with convolutional NNs

# Hyper-parameter Tuning

## *Hyper-parameter Tuning*

- Training NNs can involve setting many *hyper-parameters*
- The most common hyper-parameters include:
  - Number of layers, and number of neurons per layer
  - Initial learning rate
  - Learning rate decay schedule (e.g., decay constant)
  - Optimizer type
- Other hyper-parameters may include:
  - Regularization parameters ( $\ell_2$  penalty, dropout rate)
  - Batch size
  - Activation functions
  - Loss function
- Hyper-parameter tuning can be time-consuming for larger NNs

# Hyper-parameter Tuning

## *Hyper-parameter Tuning*

- **Grid search**
  - Check all values in a range with a step value
- **Random search**
  - Randomly sample values for the parameter
  - Often preferred to grid search
- **Bayesian hyper-parameter optimization**
  - Is an active area of research

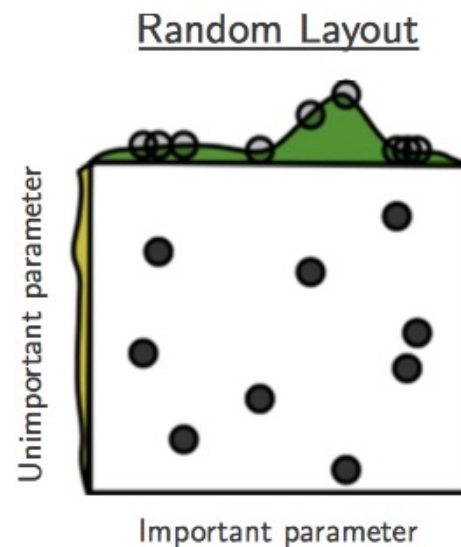
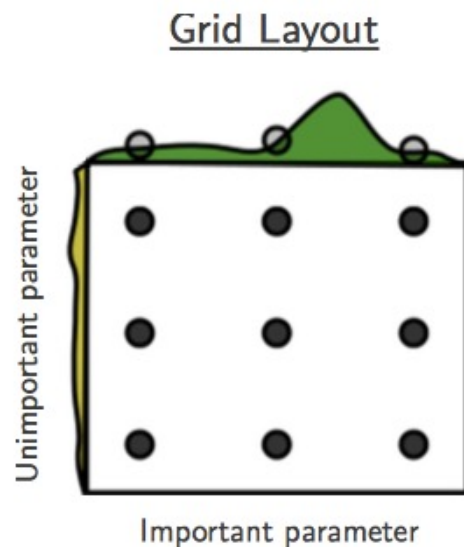



# $k$ -Fold Cross-Validation

## *k-Fold Cross-Validation*

- Using *k-fold cross-validation* for hyper-parameter tuning is common when the size of the training data is small
  - It also leads to a better and less noisy estimate of the model performance by averaging the results across several folds
- E.g., 5-fold cross-validation (see the figure on the next slide)
  1. Split the train data into 5 equal folds
  2. First use folds 2-5 for training and fold 1 for validation
  3. Repeat by using fold 2 for validation, then fold 3, fold 4, and fold 5
  4. Average the results over the 5 runs (for reporting purposes)
  5. Once the best hyper-parameters are determined, evaluate the model on the test data

# $k$ -Fold Cross-Validation

## *k*-Fold Cross-Validation

- Illustration of a 5-fold cross-validation

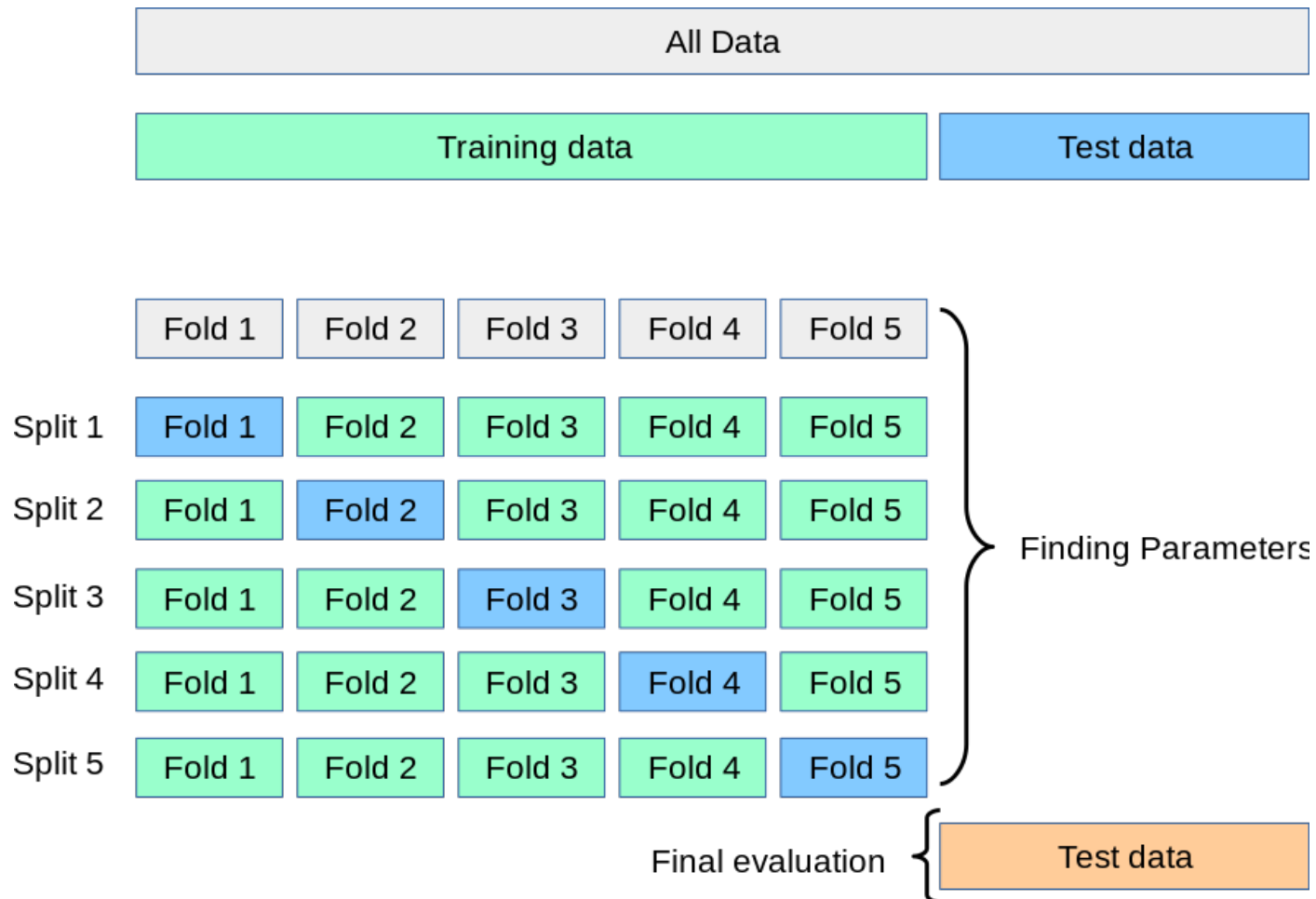

# About Lecturer

Dr. Mohamed EL Hadi Rahmani:

PhD at GeCoDe Laboratory, Computer Science department,  
Faculty of Technology, University of Saida

- **Blog:** <https://argelhadi.wordpress.com/>
- **Twitter:** [@elhadi213](https://twitter.com/elhadi213)
- **LinkedIn:** [Rahmani Mohamed Elhadi](#)
- **Email:** [elhadi213@outlook.com](mailto:elhadi213@outlook.com) / [r\\_m\\_elhadi@yahoo.fr](mailto:r_m_elhadi@yahoo.fr)