

Smart Objects

Open Source Hardware

Ioannis Chatzigiannakis

Sapienza University of Rome

Lecture 2



How do we build a smart object?



Product Development Lifecycle

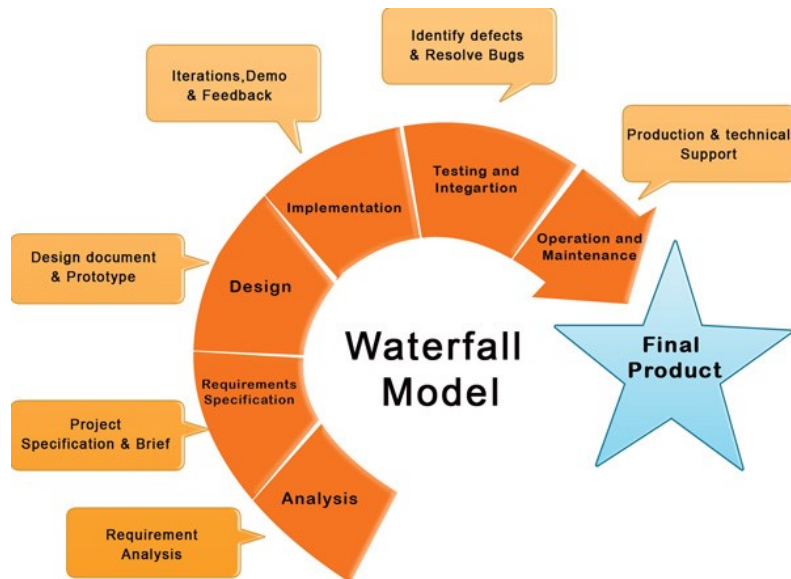

TOM FISH BURNE

© marketoonist.com



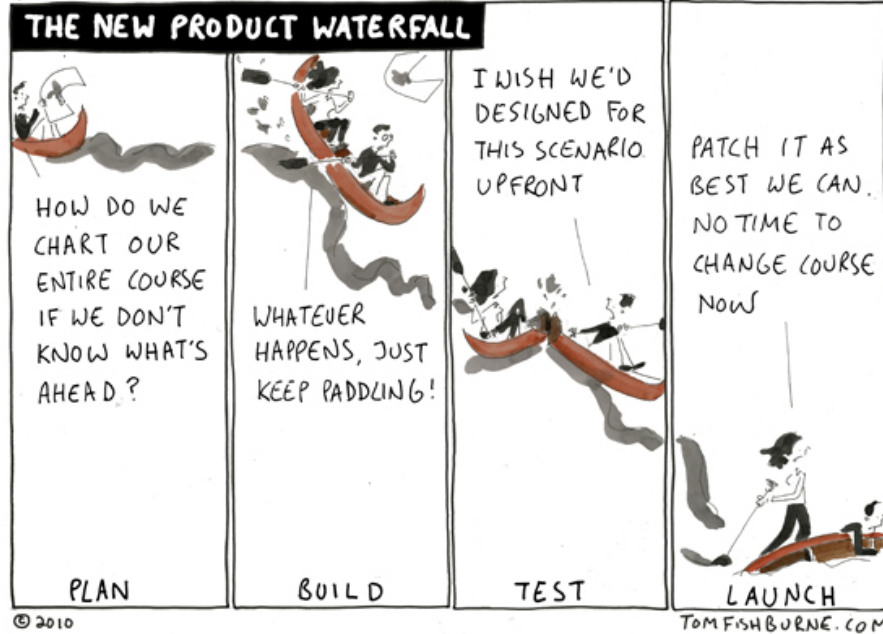

What should our smart object do?



What do the users expect from our smart object?

The Definition of User Experience (UX)

“User experience” encompasses all aspects of the end-user’s interaction with the company, its services, and its products.

Don Norman and Jakob Nielsen



The Definition of User Experience (UX)

- ▶ Meet the exact needs of the customer
- ▶ without fuss or bother
- ▶ Next comes simplicity and elegance:
produce products that are a joy to own, a joy to use.
- ▶ ... goes far beyond giving customers what they say they want
- ▶ ... go beyond checklist of features



The Definition of User Experience (UX)

“In order to achieve high-quality user experience in a company’s offerings there must be a seamless merging of the services of multiple disciplines, including engineering, marketing, graphical and industrial design, and interface design.”

Don Norman and Jakob Nielsen



How do we build a smart object?

UX Design Process



RESEARCH



DESIGN



PROTOTYPING

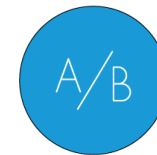

TESTING



MEASUREMENT



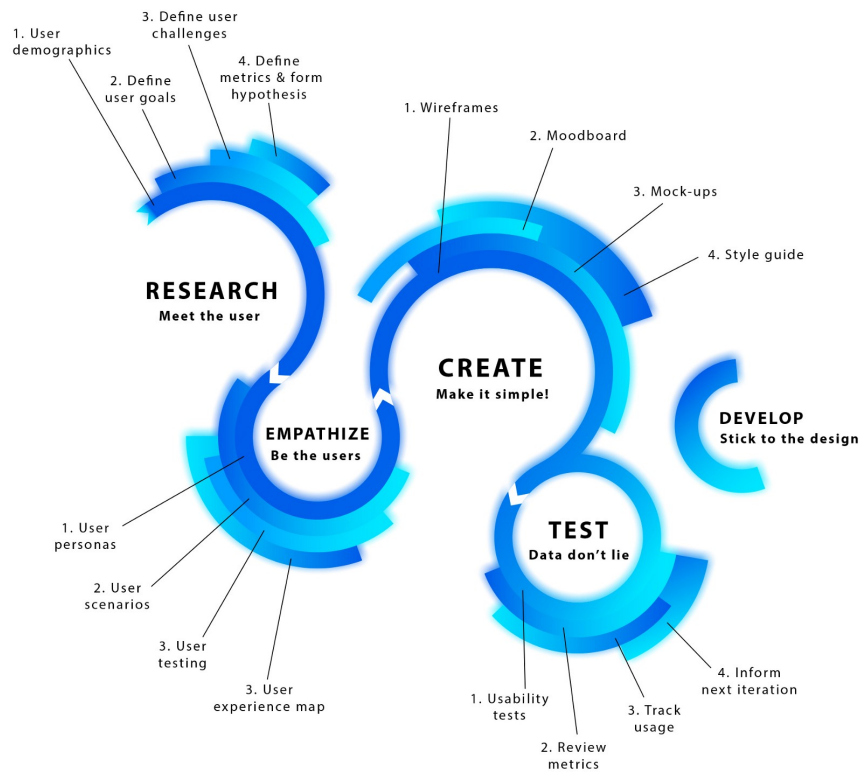

Product Development Lifecycle

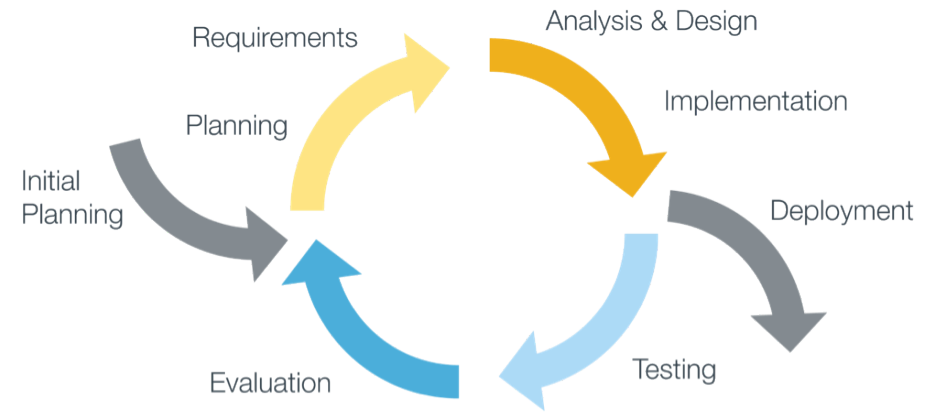

The need for a prototyping process

- ▶ Need to interact with users.
- ▶ Tangible objects convey more than story boards & wireframes.
- ▶ Mock-ups are a first important step.
 - ▶ Need for fast & low-cost mock-ups
 - ▶ 3D printing
- ▶ How can we add some **basic** functionality ?
 - ▶ Need for interactive mock-ups
 - ▶ Developing hardware prototypes require electrical engineers ?
 - ▶ Open Source Hardware.

Arduino UNO



Arduino UNO

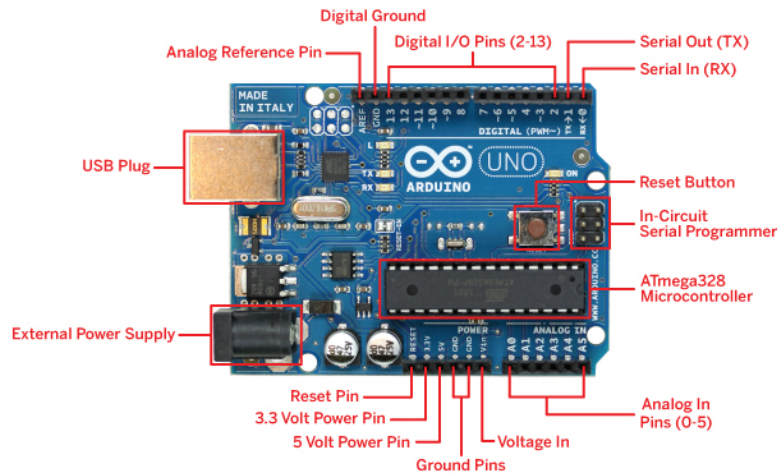

Arduino UNO components

USB Plug:

1. Power Arduino
2. Exchange Data with PC
3. Receive new program

External Power Supply:

1. Recommended: 7 ... 12 V
2. Limit: 6 ... 20 V

ATmega328P Microcontroller:

1. 32KBytes FLASH (program)
2. 1KBytes EEPROM
3. 2KBytes Internal SRAM
4. Clock: 16MHz (\approx 20)

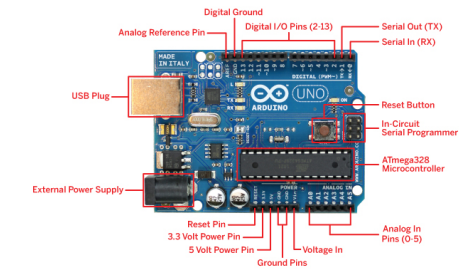

Input/Output:

1. 14 Digital I/O
2. 6 PWM Digital
3. 6 Analog Inputs

Sense-Think-Act Paradigm

Sense-Think-Act is a popular interaction paradigm

1. **Sense** – observe the environment
2. **Think** – based on the observation, make a decision
3. **Act** – based on the decision, perform some action(s)

Sense-Think-Act: Physical Computing

Almost all systems that use physical computing will have a combination of the following

1. **Sense** → **Input** – signal/informing going into the boards
 - ▶ Buttons Switches, Light Sensors, Flex Sensors, Humidity Sensors, Temperature Sensors ...
 - ▶ Internet Services (next semester)
2. **Think** → **Processing** – processing of input, internal processing, decision making
3. **Act** → **Output** – signal/information going out of the boards
 - ▶ LEDs, DC motor, servo motor, a piezo buzzer, relay, an RGB LED ...
 - ▶ Internet Services (next semester)

External Components for Sensing and Acting

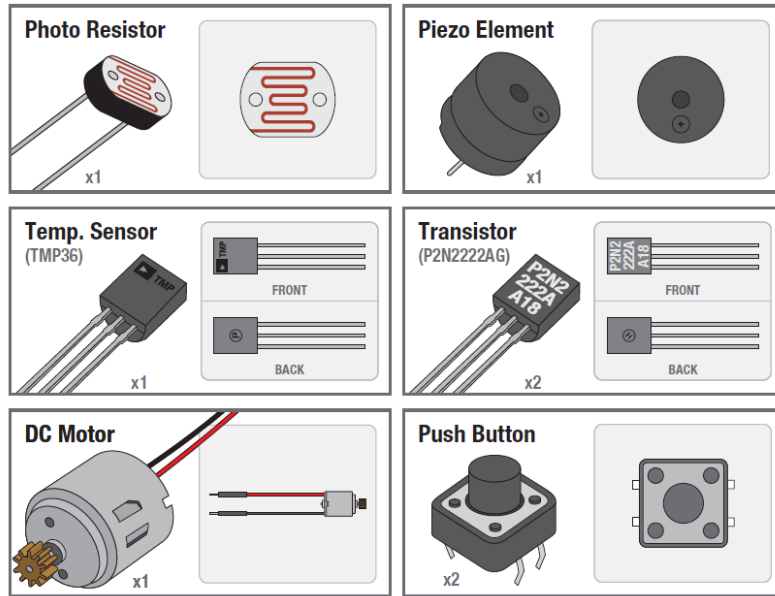

External Components for Sensing and Acting

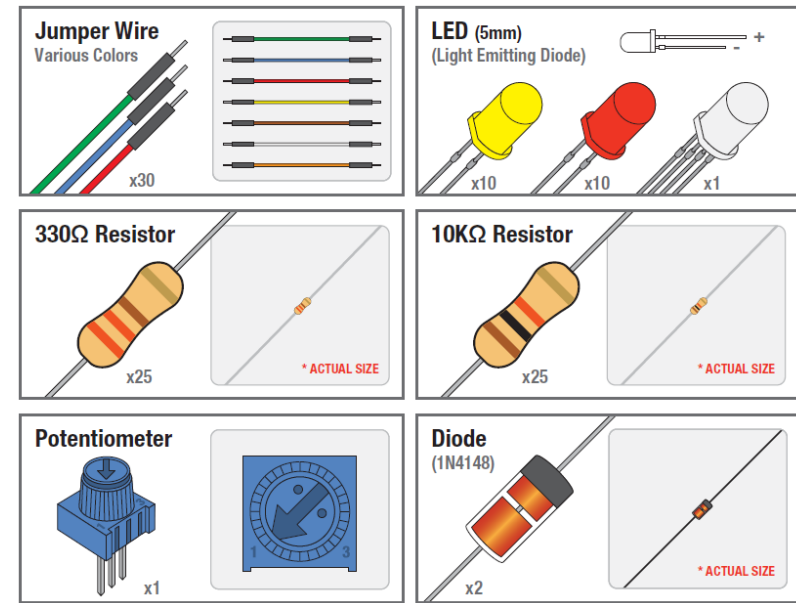

External Components for Sensing and Acting

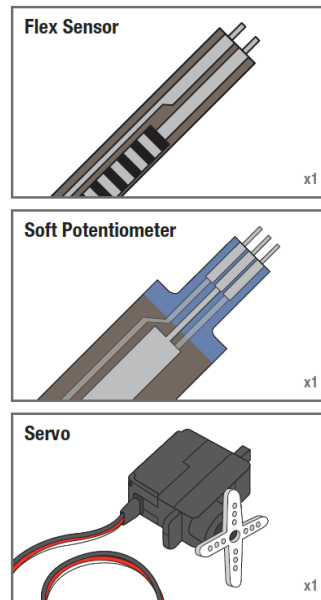

Prototyping Circuits Solderless Breadboard

One of the most useful tool.

- ▶ A breadboard is easier than soldering
- ▶ A lot of those little holes are connected, which ones?
- ▶ Sometimes breadboards break

Each row (horiz.) of 5 holes are connected.

Vertical columns called power bus are connected vertically

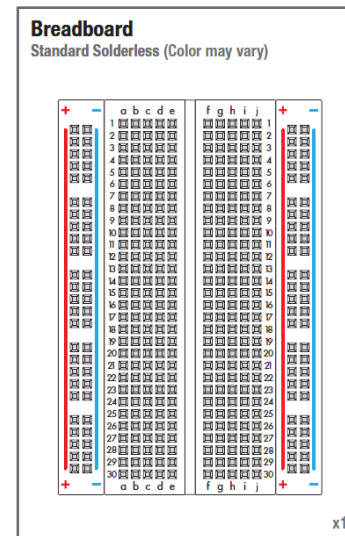

A Simple Example

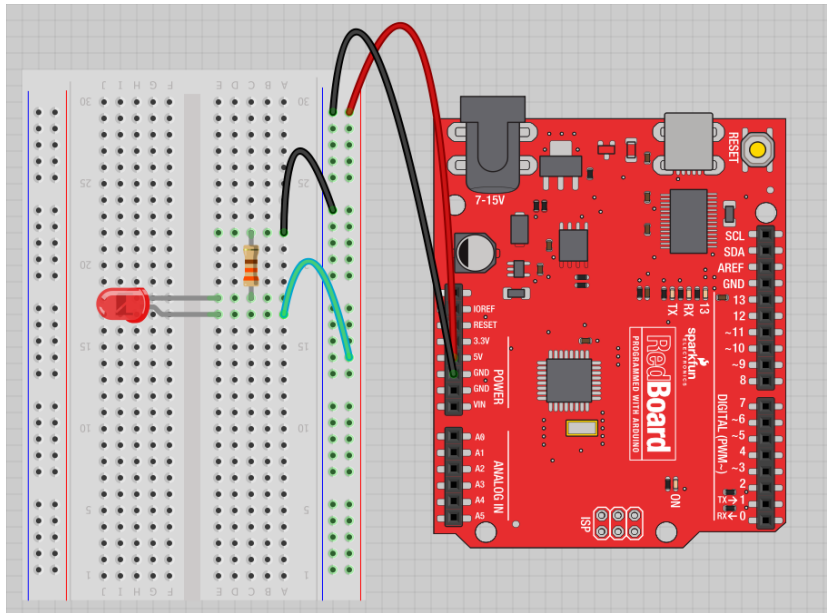

Type of External Components

Name	Image	Type	Function	Notes
Push Button		Digital Input	Switch - Closes or opens circuit	Polarized, needs resistor
Trim potentiometer		Analog Input	Variable resistor	Also called a Trimpot.
Photoresistor		Analog Input	Light Dependent Resistor (LDR)	Resistance varies with light.
Relay		Digital Output	Switch driven by a small signal	Used to control larger voltages
Temp Sensor		Analog Input	Temp Dependent Resistor	
Flex Sensor		Analog Input	Variable resistor	
Soft Trimpot		Analog Input	Variable resistor	Careful of shaft
RGB LED		Dig & Analog Output	16,777,216 different colors	Ooh... So precise

Analog vs Digital Input/Output

Microcontrollers are digital devices

- ▶ ON or OFF
- ▶ Digital signals are discrete
- ▶ Analog signals are anything that can be a full range of values.
- ▶ Discrete NOT continuous

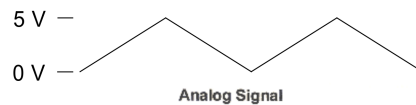
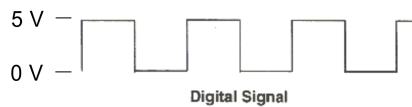

Converting Analog value to Digital

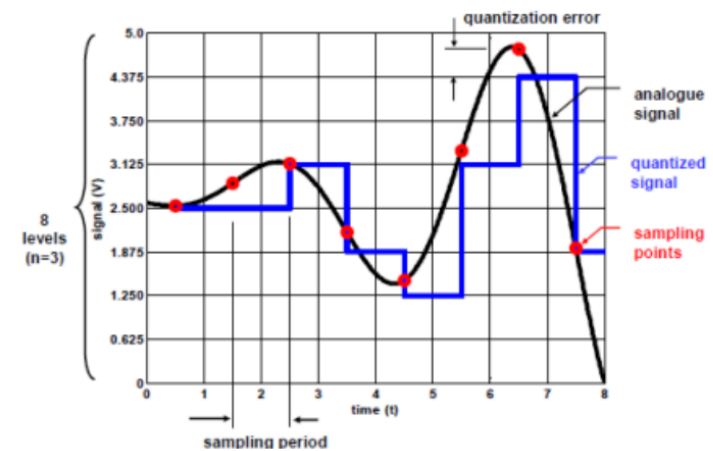

ADC – Analog to Digital Converter

1. contains 6 pins for ADC
2. 10-bit analog to digital converter
3. Maps input voltages 0 ... 5 volts → number between 0 ... 1023

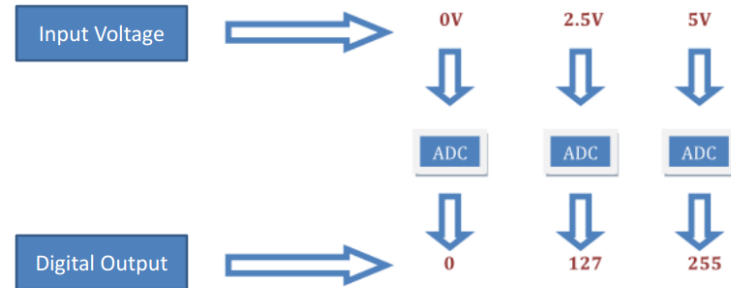

A Smart Deskstop Lamp

- ▶ Motion-controlled Lamp
- ▶ User is approaching – turn on lights.
- ▶ No user present – turn off lights.
- ▶ How do we sense if user is present?
 - ▶ Multiple ways
 - ▶ One possible way: Ultrasonic Sensor (Cost: 4 €)
- ▶ How do we switch on/off the lamp?
 - ▶ Multiple ways
 - ▶ One possible way: Relay (Cost: 2 €)

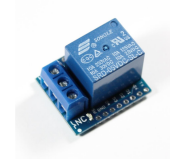

A Smart Deskstop Lamp: A simplified schema

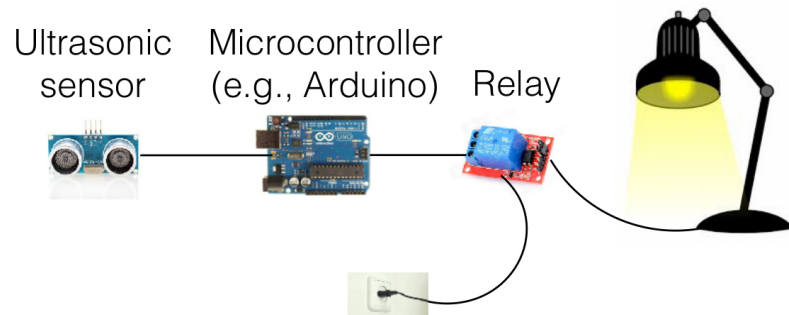

- ▶ The ultrasonic sensor measures the distance to the closest object
- ▶ Arduino reads the measurement
- ▶ If the distance is small enough, Arduino switches the relay on
- ▶ The relay lets the current flow and the lamp switch on
- ▶ If the distance is large, Arduino switches the relay off
- ▶ The relay interrupts the current flow and the lamp switches off



Many possibilities

- ▶ Change Relay → Servo
- ▶ Multiple Relays
- ▶ Multiple Ultrasonic Sensors
- ▶ ...



Different Arduino Boards



Arduino Uno



Arduino Leonardo



Arduino Ethernet



Arduino Pro



Arduino Mega 2560

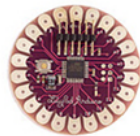

Arduino LilyPad



Arduino BT



Arduino Nano



Arduino Mega ADK



Arduino Fio



USB/Serial Light Adapter



Arduino Mini



Open Source Hardware

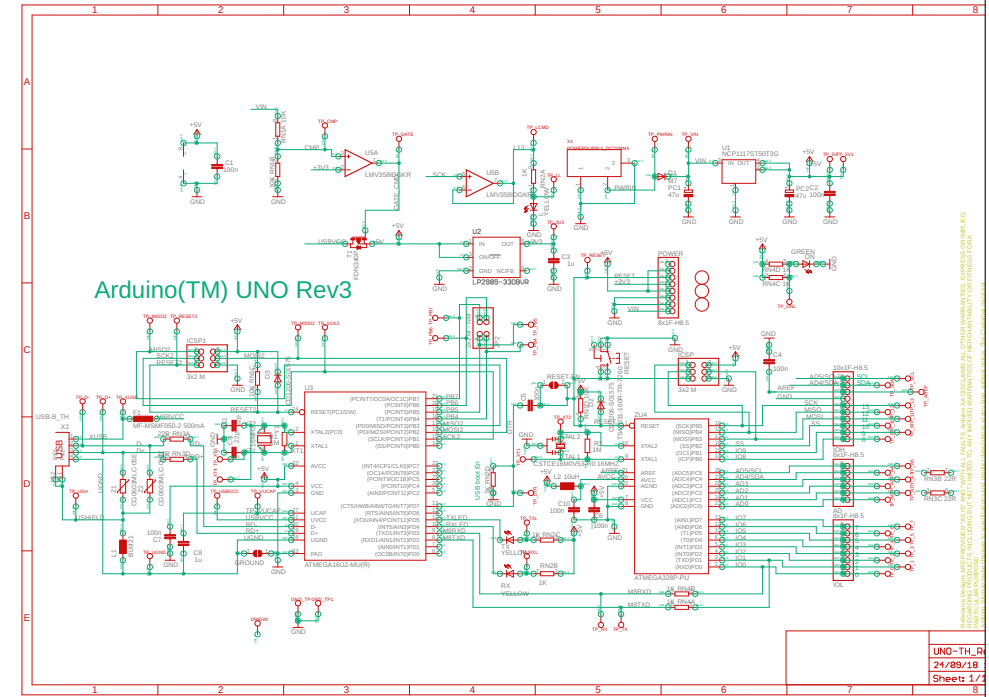

MicroBit

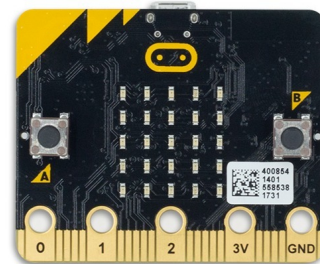
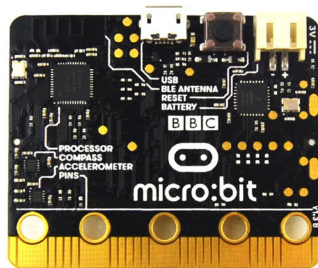

- ▶ designed by the BBC for use in computer education in the UK
- ▶ teach broad audience how to program
- ▶ targeting schools & K-12



MicroBit - Components

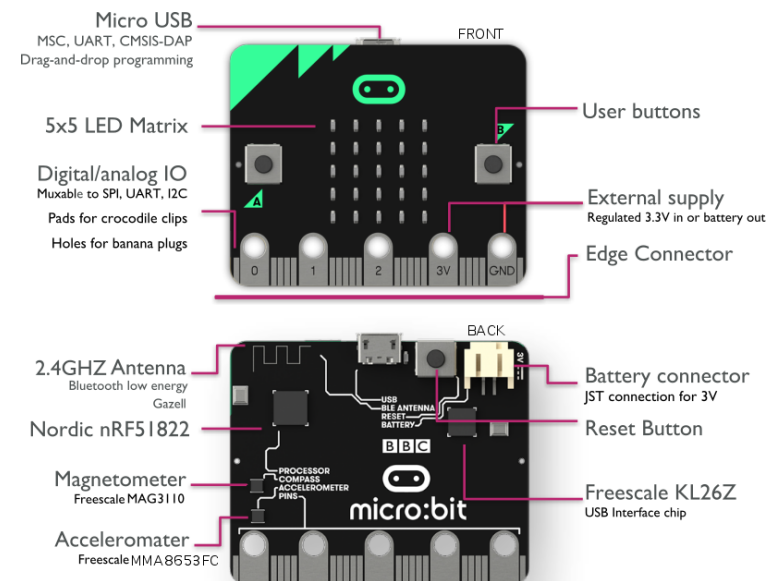

MicroBit - Micro Code Environment

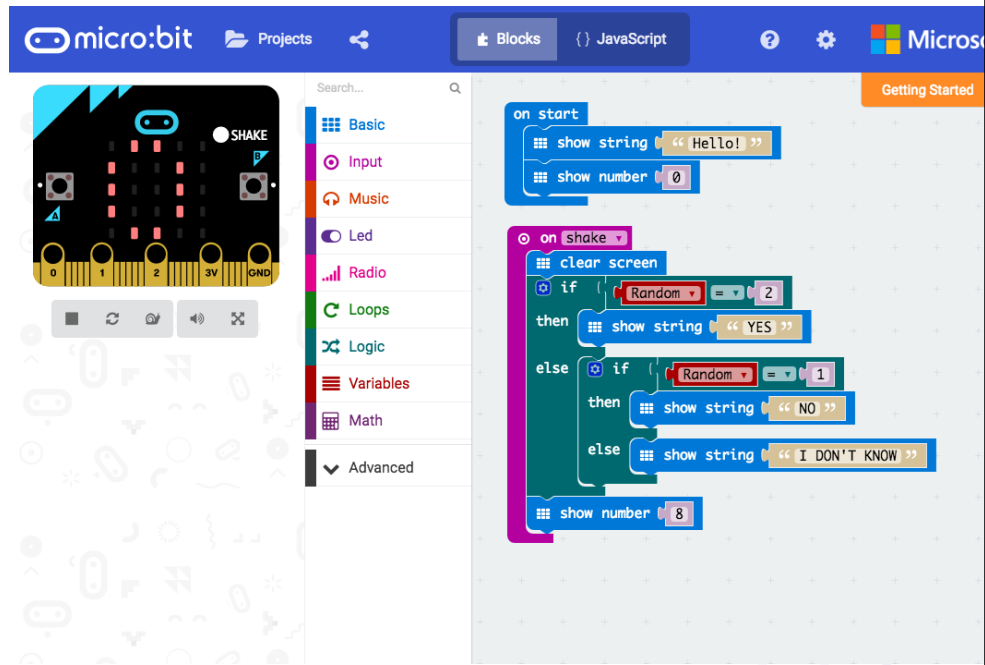

MicroBit – Details

Micro USB Plug

- ▶ Power
- ▶ Program



nRF51822 ARM Cortex-M0:

1. 256KBytes FLASH (program)
2. 16KBytes Internal SRAM
3. Clock: 16MHz
4. Bluetooth LE

Input/Output:

1. 17 Digital I/O
2. 3 PWM Digital
3. 6 Analog Inputs
4. SPI
5. I2C
6. 2 Buttons

3-axis accelerometer sensor

25 LEDs in a 5x5 array

Cost: 27 €



LilyPad Arduino

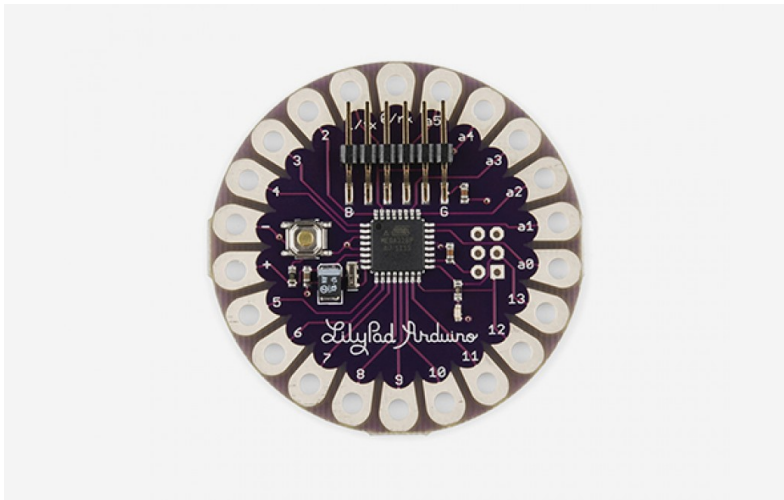

LilyPad Arduino – Components

The LilyPad Arduino “Simple” Board

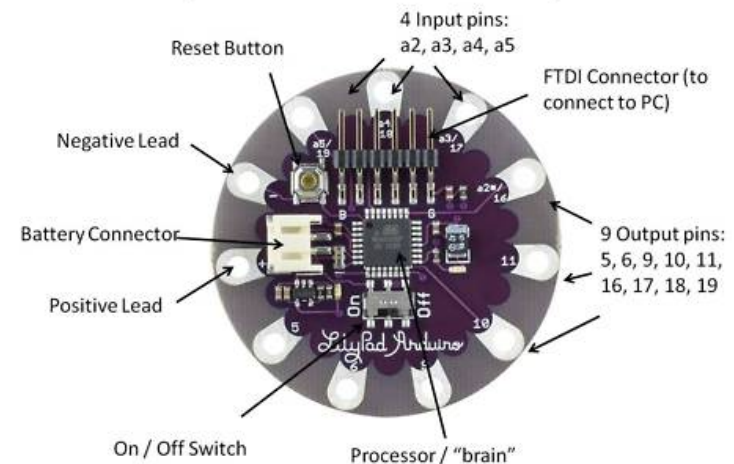

LilyPad Arduino – Details

FTDI connector

- ▶ USB Plug

LiPo charger/power Supply

ATmega168 Microcontroller:

1. 16KBytes FLASH (program)
2. 1KBytes Internal SRAM
3. Clock: 32MHz

Cost: 18 €

The LilyPad Arduino “Simple” Board

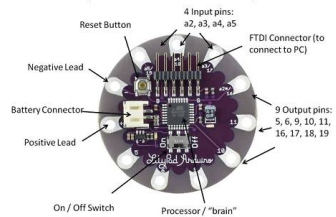

Input/Output:

1. 14 Digital I/O
2. 6 PWM Digital
3. 6 Analog Inputs

Arduino/Genuino 101

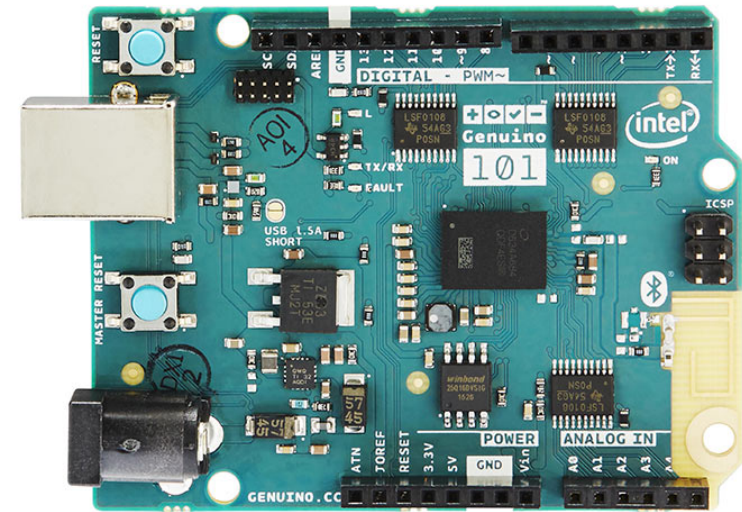

Arduino/Genuino 101 – Components

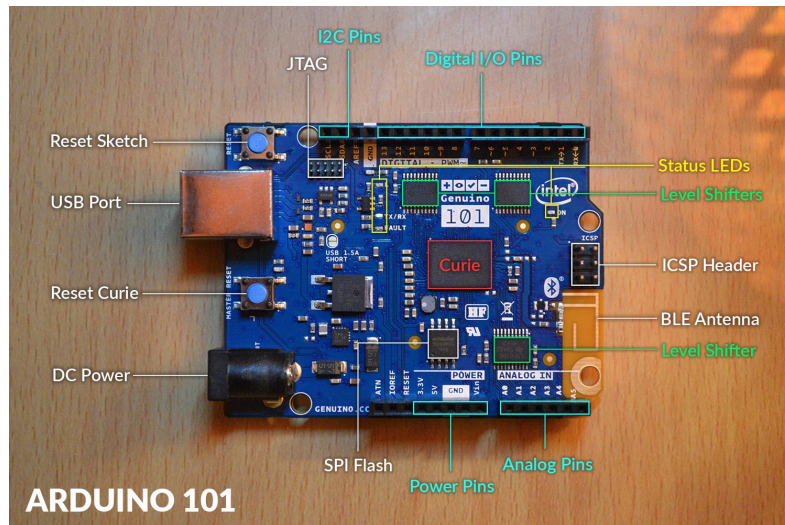

Arduino/Genuino 101 – Details

USB Plug

External Power Supply:

- ▶ Similar to Arduino Uno

Intel Curie Microcontroller:

1. 196KBytes FLASH (program)
2. 24KBytes Internal SRAM
3. Clock: 32MHz
4. Bluetooth LE
5. 6-axis accelerometer/gyro
6. Neural Network Pattern Matching Engine

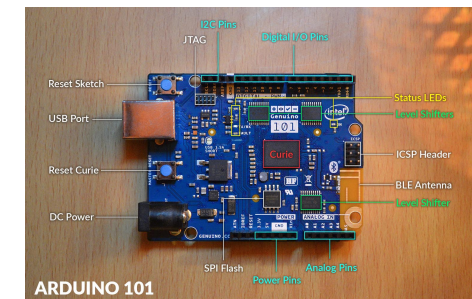

Input/Output:

1. 14 Digital I/O
2. 4 PWM Digital
3. 6 Analog Inputs

Cost: 40\$

NodeMCU ESP8266

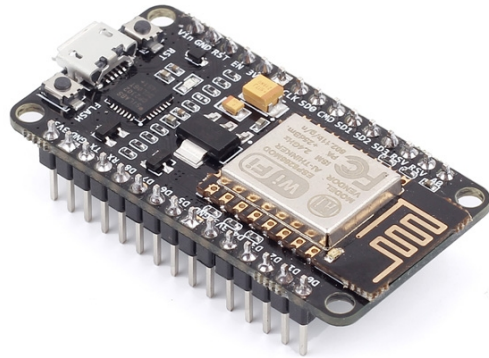

NodeMCU ESP8266 – Components

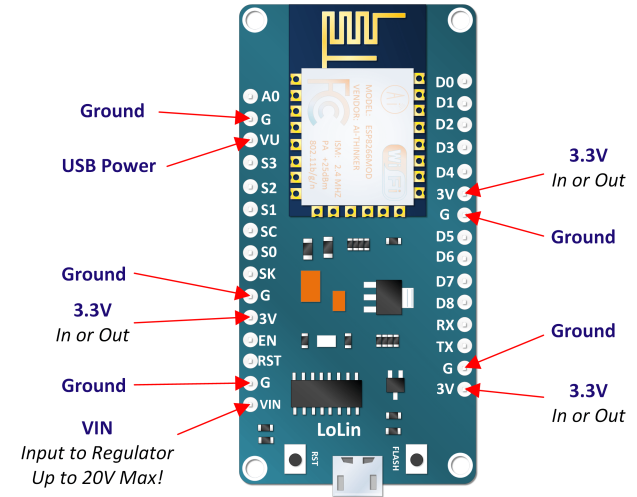

NodeMCU ESP8266 – Details

Micro USB Plug

LiPo charger/power supply

Tensilica L106 32-bit RISC

Microcontroller:

1. 32KBytes FLASH (program)
2. 128KBytes Internal SRAM
3. Clock: 80MHz
4. 802.11 b/g/n WiFi

Cost: 2\$

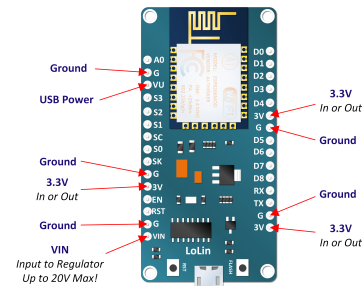

Input/Output:

1. 16 Digital I/O
2. SPI
3. I2C

Spark Core/Photon



Spark Core/Photon – Components

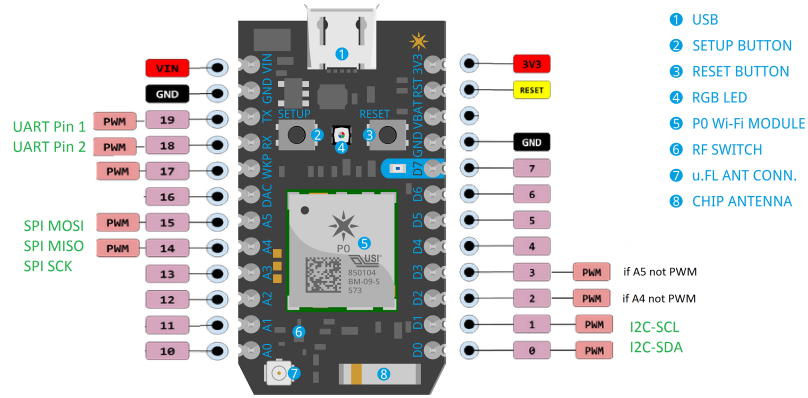

Spark Core/Photon – Details

Micro USB Plug

STM32F205 120Mhz ARM Cortex M3:

1. 1MBytes FLASH (program)
2. 128KBytes Internal SRAM
3. Clock: 120Mhz
4. 802.11 b/g/n WiFi

Device Cloud

1. Over the Air Update
2. Device Management
3. Fully Managed Connectivity

Cost: 10\$

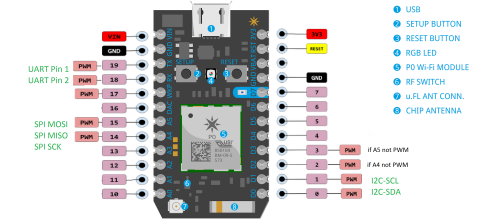

Input/Output:

1. 18 Digital I/O
2. 9 PWM Digital
3. 8 Analog Input
4. SPI
5. I2C

Seeeduino LoraWAN

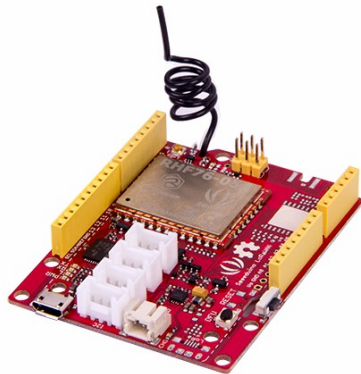

Seeeduino LoraWAN – Components

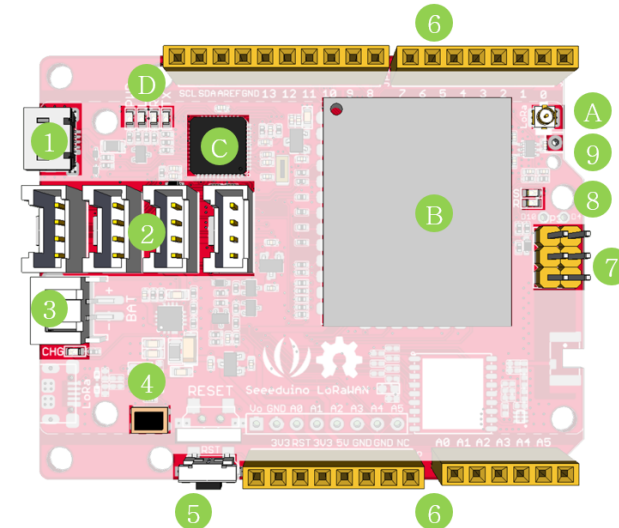

Seeeduino LoraWAN – Details

Micro USB Plug

JST2.0 Lipo battery input

ATSAMD21G18 32-Bit ARM

Cortex M0+:

1. 256KBytes FLASH (program)
2. 32KBytes Internal SRAM
3. Clock: 48Mhz

LoRaWAN

GPS Receiver

Cost: 49\$

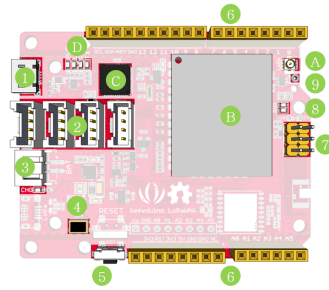

Input/Output:

1. 20 Digital I/O
2. 1 PWM Digital
3. 6 Analog Input
4. 4 Grove Connectors



Raspberry Pi



Raspberry Pi – Components

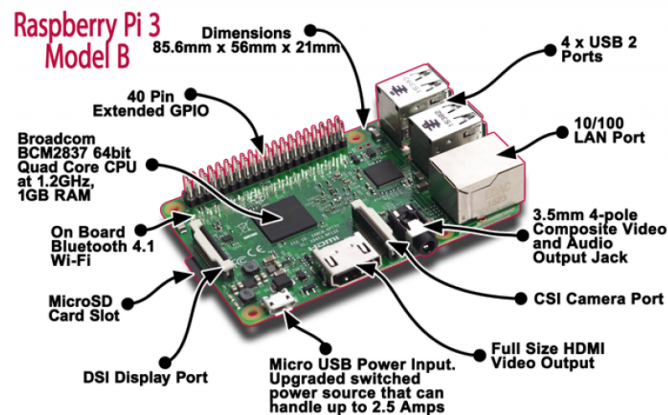

Raspberry Pi – Details

Broadcom BCM2837

4 × ARM Cortex-A53:

1. 1GB SDRAM
2. Clock: 1.2GHz

Storage: microSD

Networking

1. 10/100 Ethernet
2. 2.4GHz 802.11n
3. Bluetooth LE

GPU: Broadcom VideoCore IV @ 400 MHz

Cost: 36€

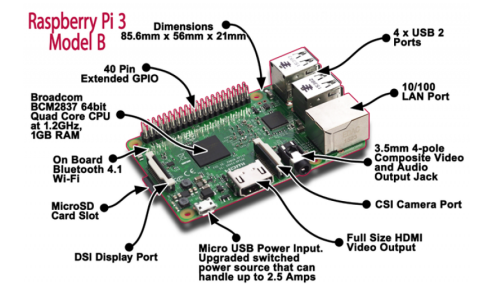

Input/Output:

1. 40 GPIO
2. HDMI
3. Audio
4. 4 USB

Further Reading

1. *Usability 101: Introduction to Usability*

<https://www.nngroup.com/articles/usability-101-introduction-to-usability/>

2. Geoffrey Moore: *Crossing the Chasm*

3. Make: Magazine

<https://makezine.com/>

4. Instructables

<https://www.instructables.com/>

5. Hackster

<https://www.hackster.io/>

6. Adafruit

<https://www.adafruit.com/>

7. Seeedstudio

<https://www.seeedstudio.com/>

8. Sparkfun

<https://www.sparkfun.com/>

9. Getting Started with the Arduino/Genuino 101

<https://www.arduino.cc/en/Guide/Arduino101>

